

OPERATOR'S MANUAL

FP-500H Firewood Processor

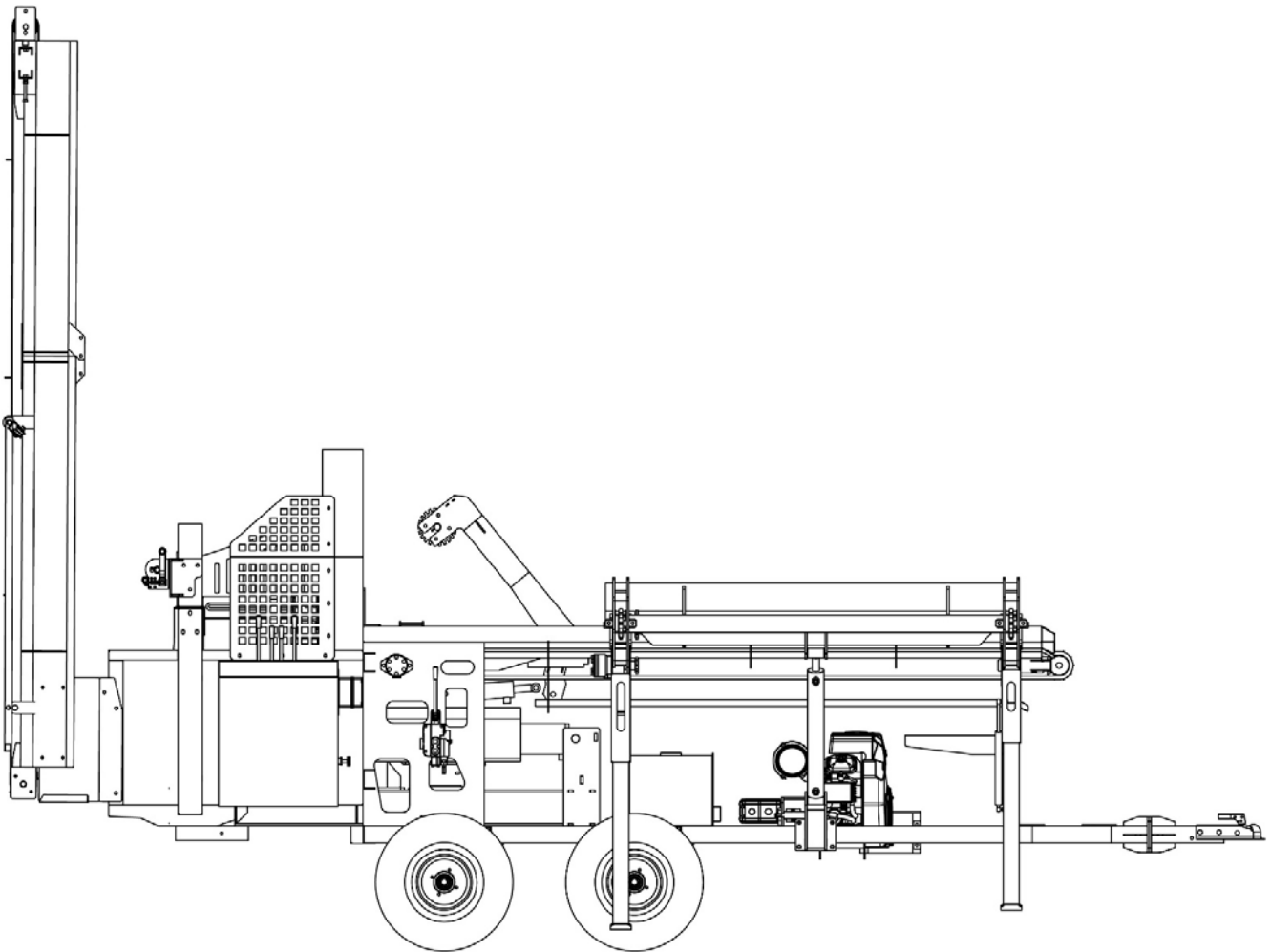

1. Introduction

1.1 Foreword

Congratulations on choosing a **FP-500H Wood Processor!**

This high-quality machine is designed and manufactured to meet the needs of a proficient timber or woodlot industry.

The FP-500H Wood Processor improves firewood productivity, ergonomics and minimizes handling. The firewood processor saves time and money while reducing the risk of physical strain.

The FP-500H consists of a hydraulic power source, live deck, infeed conveyor, and wood splitter. A 22HP gas engine drives hydraulic pumps to power the system. An optional Log Lifter can be mounted directly to the live deck. Integrated stacking conveyors are available in 8 ft (2.4 m) and 12 ft (3.6 m) lengths. Trailer-type conveyors are available in 16 ft (4.8 m) and 24 ft (7.3 m) lengths.

Logs are set onto the live deck and deck chains carry them to the infeed conveyor. The conveyor moves the logs ahead into the saw. The saw cuts the blocks to length and they fall into the splitting cradle. The wedge then splits the logs and the pieces are pushed out onto a pile or conveyor (if equipped).

The FP-500H is able to split wood up to 24" (61 cm) in length. See *Specifications on page 65* for more product information.

Safe, efficient and trouble free operation of your wood processor requires that you and anyone else who will be using or maintaining the wood processor, read and understand the Safety, Operation, Maintenance and Trouble Shooting information contained within the Operator's Manual.

Keep this manual handy for frequent reference and to pass on to new operators or owners. Call your dealer or the Distributor if you need assistance, information or additional copies of the manuals.

WARNING!

Do not attempt to start or operate the machine without thoroughly reviewing this manual for safe and proper operation.

Always keep this manual with the machine.

W034



Table of Contents

1. Introduction	2	Transporting	47
1.1 Foreword.....	2	7.1 Attaching and Unhooking.....	48
1.2 Delivery Inspection Report.....	4	7.2 Transporting on a Roadway.....	49
1.3 Serial Number Location.....	5	7.3 Trailer Breakaway System.....	49
1.4 Warranty.....	6	8. Storage	51
1.5 Product Decal Identification.....	7	8.1 Placing Wood Processor in Storage.....	51
2. Safety	8	8.2 Removing from Storage.....	51
2.1 Safety Alert Symbol.....	8	9. Service and Maintenance	51
2.2 Signal Words.....	8	9.1 Fluids and Lubricants.....	51
2.3 Why is SAFETY important?.....	9	9.2 Maintenance Schedule.....	52
2.4 Safety Rules.....	9	9.3 Greasing.....	53
2.5 Safety Training.....	10	9.4 Hydraulic Oil – Changing.....	54
2.6 Operating Safety.....	10	9.5 Engine.....	56
2.7 Equipment Safety Guidelines.....	11	9.6 Engine Air Cleaner.....	56
2.9 Sign-Off Form.....	15	9.7 Servicing the Battery.....	57
2.10 Safety Sign Explanations.....	16	9.8 Electrical System – General.....	58
3. Familiarization	21	9.9 Axles and Suspension.....	58
3.1 To the New Operator or Owner.....	21	9.10 Saw Chain Maintenance.....	59
3.2 Operator Orientation.....	21	9.11 Saw Lubrication.....	60
3.3 Job Site Familiarization.....	21	9.12 Splitting Wedge, Changing.....	61
3.1 Machine Components.....	22	9.13 Infeed Conveyor Chain, Tensioning.....	61
3.4 Engine Controls.....	23	9.14 Live Deck Chain, Tensioning.....	62
3.2 Hydraulic Controls.....	24	9.15 Live Deck Drive Chain, Tensioning.....	62
3.3 Hydraulic Control Symbols.....	24	10. Troubleshooting	63
4. Machine Set-up	26	11. Specifications	65
4.1 Positioning Machine at Site.....	26	11.1 Common Bolt Torque Values.....	67
4.2 Lowering Live Deck.....	27	11.3 Hydraulic Fitting Torque.....	68
4.3 Lowering Live Deck with Log Lifter.....	28	11.2 Wheel Lug Nut Torque.....	68
4.4 Raising Live Deck with Log Lifter.....	31	12. Accessories	69
4.5 Block Dropper.....	31	12.1 Operator's Platform.....	69
4.6 Log Stop Guide.....	32	12.2 Integrated Conveyor.....	69
4.7 Saw Shield.....	33	13. Alphabetical Index	72
4.8 Integrated Conveyor Set-up.....	33		
4.9 Making the Work Area Safe.....	34		
5. Pre-start Checks	35		
5.1 Pre-Operation Checklist.....	35		
5.2 Before Starting the Engine.....	35		
5.3 Fuel Level Check.....	36		
5.4 Engine Oil Level Check.....	36		
5.5 Hydraulic Oil Level Check.....	37		
5.6 Chain Saw Bar Oil level.....	37		
5.7 Saw Chain – Checking.....	37		
5.8 Machine Break-In.....	38		
6. Operation	39		
6.1 Starting the Engine.....	39		
6.2 Live Deck.....	40		
6.6 Log Lifter (optional).....	41		
6.3 Infeed Conveyor.....	42		
6.4 Cutting.....	44		
6.5 Splitting.....	45		
7.			

1.2 Delivery Inspection Report

FP-500H Trailer Firewood Processor To activate warranty, register your product online at

This form must be filled out by the dealer and signed by both the dealer and the customer at the time of delivery.

Customer's Name

Contact Name

Dealer Name

(_____) _____
Phone Number

Serial Number

_____/_____/_____
Delivery Date (dd/mm/yy)

I have thoroughly instructed the buyer on the equipment care, adjustments, safe operation and applicable warranty policy and reviewed the manuals.

Dealer's Rep. Signature

_____/_____/_____
Delivery Date (dd/mm/yy)

The product manuals have been received by me and I have been thoroughly instructed as to care, adjustments, safe operation and applicable warranty policy.

Owner's Signature

_____/_____/_____
Delivery Date (dd/mm/yy)

Pre-delivery Inspection	
Inspect for damage from shipping. Immediately contact the shipping company if damage is found.	
Wood Processor	
	Engine Starts and Runs
	All Valve Controls Function
	All Cylinders and Motors Function
	Wedge Height Adjuster Functions
	Live Deck Chains Tight
	Infeed Chains Tight
	Fasteners Tight
	Saw Chain Tensioned Properly
	Hydraulic Connections Tight
	Bar Oil Reservoir Filled, or User Instructed to Fill. Flow Control Open
	Verify Bar Oiler Motor Functions and Oils Saw Chain after Reservoir is Filled
	Verify Function of Trailer Turn, Signal, and Stop Lights
	Grease Machine
	Review Operating and Safety Instructions
Safety Checks	
	All Safety Decals Installed
	Guards and Shields Installed and Secured
	All Jacks Function
	Retainer Installed Through Hitch Points
	Check Tire Pressure
	Check Wheel Nuts
	Check Operation of Running / Brake Lights
	Review Operating and Safety Instructions
Optional Equipment	

1.3 Serial Number Location

Always provide the serial number of your product when ordering parts or requesting service or other information. The Serial Number Plate location is shown in the illustration.

Record the product Serial Number in the space provided below for future reference.

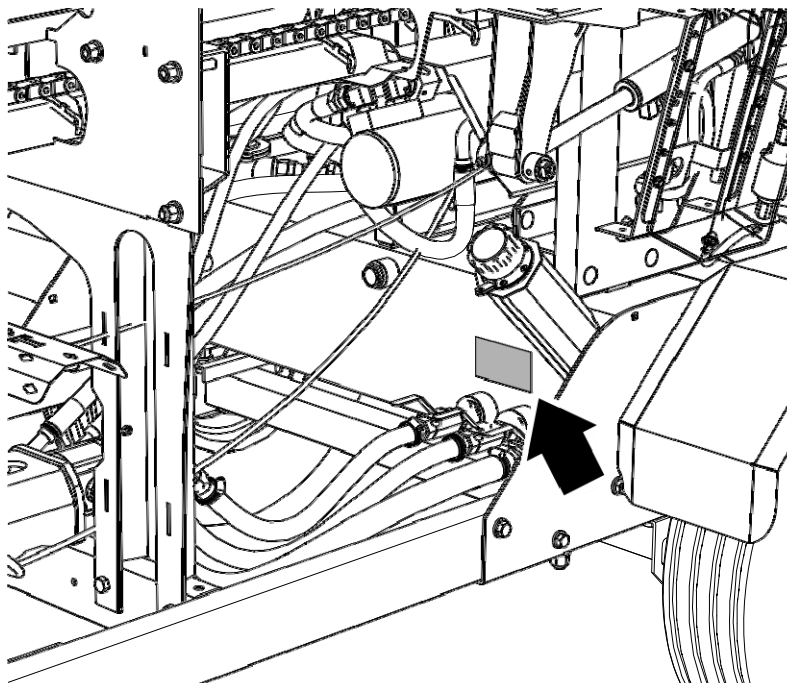

00442

Fig. 1 – Serial Number Plate Location

Record Product Information Here	
Model:	FP-500H
Serial Number:	

1.4 Warranty

LIMITED WARRANTY

Products are warranted to be free of defects in materials and workmanship under normal use and service, for a period of

1.5 Years for Consumer Use

1 Year for Commercial/Rental Use

from the date of purchase, when operated and maintained in accordance with the operating and maintenance instructions supplied with the unit. Warranty is limited to the repair of the product and/or replacement of parts.

This warranty is extended only to the original purchaser and is not transferable.

Repairs must be done by an authorized dealer. Products will be returned to the dealer at the customer's expense. Include the original purchase receipt with any claim.

This warranty does not cover the following:

- 1) Normal maintenance or adjustments
- 2) Normal replacement of wearable and service parts
- 3) Consequential damage, indirect damage, or loss of profits
- 4) Damages resulting from:
 - Misuse, negligence, accident, theft or fire
 - Use of improper or insufficient fuel, fluids or lubricants
 - Use of parts or aftermarket accessories other than genuine parts
 - Modifications, alteration, tampering or improper repair performed by parties other than an authorized dealer
 - Any device or accessories installed by parties other than an authorized dealer
- 5) Engines. Engines are covered by the manufacturer of the engine for the warranty period they specify. For the details of your engine warranty, see your engine owner's manual. Information about engine warranty and service is also available in the FAQ section at Our website

1.5 Product Decal Identification

There are different types of decals on products. These decals provide safety warnings, operating information, and product identification. The following information describes each type.

Safety Signs have a yellow background and two panels. The top panel shows the safety alert (the potential hazard) and the bottom panel shows the message (how to avoid the hazard).

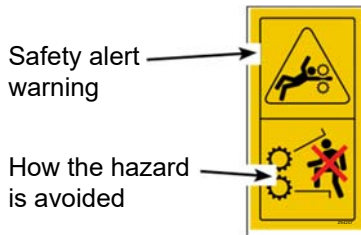

See *Safety Signs* on page 16 for further explanation.

Safety Notice decals have a blue background and are generally rectangular with single or multiple symbols. This decal shows suggested PPE requirements for safe operation.



Informative decals have a white background and can vary in the number of panels. These decals provide operating information on a feature of the machine.

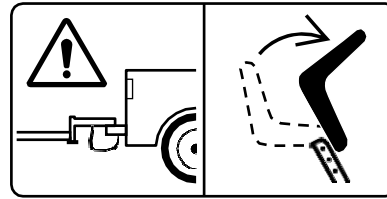

Maintenance decals have a green background. They can have various messages and vary in the number of panels. These decals indicate the maintenance type and can indicate the service interval. Maintenance decals are further explained in the Service and Maintenance section.



For complete illustrations of decal locations on the machine, download the parts manual for this product model at [Our website](#).

2. Safety

2.1 Safety Alert Symbol

This Symbol means:

**ATTENTION! BE ALERT !
YOUR SAFETY IS INVOLVED !**

The Safety Alert Symbol identifies important safety messages on the product and in the manual.

When you see this symbol, be alert to the possibility of personal injury or death! Follow the instructions in the safety message.



2.2 Signal Words

The signal words **DANGER**, **WARNING** and **CAUTION** determine the seriousness level of the warning messages in this manual. The appropriate signal word for each message in this manual has been selected using the following guidelines:

DANGER –

Indicates an imminently hazardous situation that, if not avoided, **will** result in death or serious injury. This signal word is to be limited to the most extreme situations typically for machine components which, for functional purposes, cannot be guarded.

WARNING –

Indicates a potentially hazardous situation that, if not avoided, **could** result in death or serious injury, and includes hazards that are exposed when guards are removed. It may also be used to alert against unsafe practices.

CAUTION –

Indicates a potentially hazardous situation that, if not avoided, **may** result in minor or moderate injury. It may also be used to alert against unsafe practices.

IMPORTANT – To avoid confusing equipment protection with personal safety messages, a signal word **IMPORTANT** indicates a situation that if not avoided, could result in damage to the machine.



NOTE: *(plus text) – indicates an additional explanation for an element of information.*

2.3 Why is SAFETY important?

Three Big Reasons:

- Accidents can disable and kill
- Accidents can cause financial hardship
- Accidents can be avoided

YOU are responsible for the SAFE operation and maintenance of your trailer wood processor. **YOU** must ensure that you and anyone else who is going to use, maintain or work around the wood processor be familiar with the operating and maintenance procedures and related **SAFETY** information contained in this manual. This manual provides good safety practices that should be followed while using this machine.

Remember, **YOU** are the key to safety. Good safety practices not only protect you but also the people around you. Make these practices a working part of your safety program. Be certain that **EVERYONE** using this equipment is familiar with the recommended operating and maintenance procedures and follows all the safety precautions. Most accidents can be prevented.

Do not risk injury or death by ignoring good safety practices.

2.4 Safety Rules



- **DO** give operating instructions to operators or employees before allowing them to operate the machine.
- **DO** always wear appropriate Personal Protective Equipment (PPE). This equipment includes but is not limited to the following:
 - A hard hat
 - Heavy gloves
 - Hearing protection
 - Protective shoes with slip resistant soles
 - Protective glasses, goggles or face shield



- **DO** read and understand ALL Safety and Operating instructions in the manual and follow them. Most accidents can be avoided. The most important safety device on this equipment is a SAFE operator.
- **DO** read and understand all safety signs located on the machine before using, maintaining, adjusting or cleaning.
- **DO** inspect and secure all guards before starting.
- **Do** set the chain saw bar oil flow rate before operating the saw.
- **Do** check saw chain tension every three hours of operation. Sharpen chain daily.
- **DO** place the machine in a Safe Condition before performing any service, maintenance work, storage preparation, or hooking up.

Placing the machine in a Safe Condition involves performing the following:

SAFE CONDITION
<ol style="list-style-type: none"> 1. Clear infeed conveyor and splitting hopper. 2. Release all controls and ensure all components have stopped moving. 3. Shut off the engine. Disconnect spark plug leads. Disconnect negative (-) battery cable from battery. 4. Relieve hydraulic system pressure by actuating controls.

- **DO** have a first-aid kit available for use should the need arise. 
- **DO** have a fire extinguisher available for use should the need arise and know how to use it. 
- **DO** check the machine is clear of debris prior to starting the engine.
- **DO** review safety related items annually with all personnel who will be operating or performing maintenance.
- **DO** handle logs with respect and be aware of other operators in the area.
- **DO** think SAFETY! Work SAFELY!

- **DO NOT** touch hot engine parts, muffler cover, hoses, engine body, or engine oil during operation and after the engine has been shut off. Contact may cause burns.
- **DO NOT** expect a person who does not understand operation and safety instructions to use the machine. Untrained operators are not qualified and can create risks of serious injury or death. It is the machine owner's responsibility to make sure every operator is fully trained.
- **DO NOT** modify the equipment in any way. Unauthorized modification may impair function or safety, could affect the life of the equipment, and can void warranty.
- **DO NOT** allow riders during transport.
- **DO NOT** risk injury or death by ignoring good safety practices.
- Train all operators to be familiar with equipment's operation. The operator should be a responsible, properly trained and physically able person familiar with machinery. If the elderly are assisting with work, their physical limitations need to be recognized and accommodated.
- Wear hearing protection on a full-time basis. Prolonged exposure to loud noise may cause permanent hearing loss!
 - Noise over 85 dB on a long-term basis can cause severe hearing loss.
 - Noise over 90 dB adjacent to the Operator over a long-term basis may cause permanent, total hearing loss.



2.5 Safety Training

- Safety is a primary concern in the design and manufacture of products. Unfortunately, our efforts to provide safe equipment can be wiped out by a single careless act.
- The best safety feature is an informed, careful operator—we ask you to be that kind of an operator. It is the operator's responsibility to read, understand and follow ALL safety and operation instructions in the manual. Accidents can be avoided.
- **Do not allow anyone to use this machine until they have read this manual. Operator's must have a thorough understanding of the safety precautions and of how the machine works.** Review the safety instructions with all users annually.



- Keep bystanders away at a safe distance at least 20 ft (6 m) from stacking zone. Mark the zone with safety cones.
- Determine a safe work area / trailer location:
 - Ground should be firm and level.
 - Area must be clear of stones, branches or hidden obstacles that might cause a tripping, hooking or snagging hazard.
 - There must be no overhead hazards such as branches, cables, electrical wires and so on.
- Determine a safe split stack location:
 - Stack split wood on level ground. Make sure it does not interfere with safe operation of the machine.
- Precut to length and de-limb logs so they are ready to load onto the live deck.
- Operate the machine in daylight or good artificial light only.
- Make sure machine is properly stationed, adjusted and in good operating condition.
- Store fuel well away from the material pile.
- Perform the **Pre-operation Checklist** procedure before starting work (see *page 35*).
- Position machine so prevailing winds blow engine exhaust fumes away from operator's station.
- Do not operate on hillsides or when working area is cluttered, wet, muddy or icy to prevent slipping and tripping. Keep working area clean and free of debris.
- Stop engine if leaving the machine unattended.
- Make sure all guards, deflectors and shields are

2.6 Operating Safety

It is important that you read and pay attention to the safety signs on the wood processor. Clean or replace all safety signs if they cannot be clearly read and understood. They are there for your safety, as well as the safety of others. The safe use of this machine is strictly up to you, the operator.

All machines with moving parts are potentially hazardous. There is no substitute for a cautious, safe-minded operator who recognizes potential hazards and follows reasonable safety practices.

installed before starting and operating the machine.

- Operate the machine only when physically fit and not under the influence of alcohol, drugs or medicines that can cause drowsiness.
- Avoid loose fitting clothing, loose or uncovered long hair, jewelry and loose personal articles. These can get caught in moving parts.
- Do not allow anyone within the work or danger zone during operation.
- Place machine in a **Safe Condition** before servicing or repairing. See *Safe Condition on page 9*.
- Do not try to process more than one log at a time. The extra log can move unexpectedly and cause injury.
- Use a peavey or the provided hookaroon to reposition cut logs in the splitting chamber. Handle logs using a peavey for positioning.
- Do not try to split logs across the grain. Some logs can burst or splinter and fly out of the machine causing injury.
- When loading the live deck, do not position logs farther left than the safety whip. Be aware of others in the area when operating heavy equipment.
- Do not attempt to saw a log that is not firmly clamped in position. Chain could break and fly into pieces. Stop and reposition the log so it is stable.

2.7 Equipment Safety Guidelines

The safety of the operator and bystanders is one of the main concerns in designing and developing equipment. However, every year many accidents occur which could have been avoided by a few seconds of thought and a more careful approach to handling equipment.

- Replace any safety sign or instruction sign that is not readable or is missing. Location of such safety signs is indicated in this manual.
- **Never allow young children to work with this equipment. Do not allow persons to use this unit until they have read this manual and have developed a thorough understanding of the safety precautions and of how it works.** Review the safety instructions with all users annually.
- Never exceed the limitations of the machine. If its ability to do the job, or to do it safely is in question—**STOP!**

2.7.1 Maintenance Safety

Always place the machine in a safe service position before performing any service or maintenance work, storage preparation, or hooking / unhooking. See *Safe*

Condition on page 9.

Follow good shop practices:

- Have at least two workers present when performing maintenance on this equipment. Never work alone in case an emergency should arise.
- Keep service area clean and dry.
- Never operate the engine in a closed building. Make sure there is plenty of ventilation. Exhaust fumes can cause asphyxiation.
- Never work under unsupported equipment.
- Use only genuine OEM replacement parts. The manufacturer is not responsible for injuries or damage caused by the use of non-approved parts or accessories.
- Make sure all safety shields and devices are re-installed when a maintenance or service procedure is finished.
- Do not use gasoline or diesel fuel when cleaning any parts. Use a regular cleanser.
- Use proper tools that are in good condition. Make sure the procedure is understood before performing any service work.



2.7.2 Hydraulic System Safety

- Make sure that all the components in the hydraulic system are kept clean and in good condition.
- Make sure all components are tight, and that lines, hoses and couplings are not damaged before applying pressure to the system.
- Do not use a hand to check for hydraulic oil leaks. Hydraulic fluid escaping under pressure can penetrate the skin causing serious injury. Use a piece of cardboard.
- Wear proper hand and eye protection when searching for a high pressure hydraulic leak.
- Seek medical attention immediately if injured by a concentrated high-pressure stream of hydraulic fluid. Serious infection or toxic reaction can develop from hydraulic fluid piercing the skin surface.



- Do not attempt any makeshift repairs to the hydraulic lines, fittings or hoses by using tape, clamps or cements. Doing so can cause sudden failure and create a hazardous and unsafe condition.
- Relieve pressure on the hydraulic system before working it. The hydraulic system operates under extremely high pressure.
- Replace any hydraulic hose immediately that shows signs of swelling, wear, leaks or damage before it bursts.
- Do not bend or strike high-pressure lines, tubes or hoses, or reinstall them in a bent or damaged condition.
- Check to make sure hydraulic hoses are not worn or damaged, and are routed to avoid chafing.
- Never adjust a pressure relief valve or other pressure-limiting device to a higher pressure than specified.

2.7.3 Storage Safety

1. Store the unit in an area away from human activity.
2. Do not allow children to play on or around the stored machine.
3. Consult the engine owner's manual for storage information on the engine.

2.7.4 Transport Safety

- Comply with provincial / state laws governing safety and transporting of machinery on public roads.
- Do not exceed a safe travel speed. Slow down for rough terrain and cornering.
- Do not transport or move the wood processor with the engine running.
- Make sure all latch handles are secure.
- Make sure the trailer is hitched positively to the towing vehicle and a retainer is used through the hitch mechanism.
- Make sure safety chains between the hitch and the towing vehicle are crossed under the tongue and properly attached.
- Inspect wheel rims for dents or damage. Check wheel lug torque. Refer to table at the back of this manual.
- Inspect tires for cuts or damage. Check tire pressure and adjust if required. Refer to specification on the tire sidewall.
- Make sure the stability jacks are raised and secured with the latch pin.

- Inspect all access panels and guards to ensure they are secured.
- Check fuel and hydraulic tank caps are on tight to prevent spills while transporting.
- Clean off all debris from the machine.
- Check that all the lights, reflectors and other lighting requirements are installed and in good working condition.
- Never allow riders on the machine.
- Be a safe and courteous driver. Always yield to oncoming traffic in all situations, including narrow bridges, intersections, and so on.
- Watch for traffic when near or crossing roadways.
- Perform a final circle check before transporting.

2.7.5 Refuelling Safety

- Fuel is highly flammable. Handle with care.
- Stop the engine and allow it to cool for five minutes before refuelling. Clean up spilled fuel before restarting engine.
- Do not refuel the machine while smoking or when near open flame or sparks.



- Fill fuel tank outdoors.
- Prevent fires by keeping machine clean of accumulated trash, grease, and debris.
- Do not overfill the fuel tank. Fill until the fuel level is visible 1/2" (12 mm) below the filler neck to leave room for expansion.
- If fuel is spilled, wipe it away carefully and wait until it has dried before starting the engine.
- After refueling, make sure that the fuel cap is on securely to prevent spillage.

2.7.6 Tire Safety

- Failure to follow proper procedures when mounting a tire on a wheel or rim can produce an explosion which may result in serious injury or death.
- Do not attempt to mount a tire unless you have the proper equipment and experience to do the job.
- Have a qualified tire dealer or repair service perform required tire maintenance.
- When replacing worn tires, make sure they meet the original tire specifications.

2.7.7 Chain Saw Safety

A chain saw is inherently hazardous. Potential injuries can be minimized by using proper personal protective equipment and safe operating procedures.

Good cutting action results and chain life increases with correct chain tension. If too loose, a chain can derail; if too tight a chain can bind.

Proper chain lubrication prolongs the life of the saw and increases safety.

Sharpen the saw if:

- The chain tends to track sideways while cutting.
- The cut shows fine powder instead of chips.
- There is a burnt wood smell.

Never use a saw chain that:

- Has broken twice.
- Is severely damaged.
- Has excessive saw chain stretch.
- Has broken or cracked components.
- Has loose rivet joints. If you can rotate the rivets with your fingers, they are too loose.

2.7.8 Battery Safety

- Wear gloves and safety glasses or face shield when working on or near batteries.
- Use a battery carrier to lift the battery or place hands at opposite corners to avoid spilling acid through the vents.
- Avoid contact with battery electrolyte:
 - **External Contact:** Flush immediately with water.
 - **Eye Contact:** Flush with water for 15 minutes. Get prompt medical attention. Clean up any spilled electrolyte immediately.
- Avoid contact with battery posts, terminals and related accessories. They contain lead and lead compounds, chemicals known to cause harm. Wash hands immediately after handling.
- Keep all sparks and flames away from batteries. Gases given off by electrolyte is explosive.
- To avoid injury from spark or short circuit, disconnect battery ground cable before servicing any part of the electrical system.

- Frozen batteries can explode and result in death or serious injury. Do not jump start or charge a frozen battery. Let battery thaw before charging.

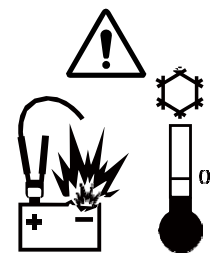

2.7.9 Gas Engine Safety

- **DO NOT** run engine in an enclosed area. Exhaust gases contain carbon monoxide, which is an odorless and deadly gas.
- **DO NOT** place hands or feet near moving or rotating parts.
- **DO NOT** choke carburetor to stop engine. Whenever possible, gradually reduce engine speed before stopping.
- **DO NOT** tamper with governor springs, governor links or other parts which may increase the governed speed. Engine speed is selected by the original equipment manufacturer.
- **DO NOT** check for spark with spark plug or spark plug wire removed.
- **DO NOT** crank engine with spark plug removed. If engine is flooded, crank until engine starts.
- **DO NOT** strike flywheel with a hard object or metal tool as this may cause flywheel to shatter in operation. Use proper tools to service engine.
- **DO NOT** operate engine without a muffler or heat shield. Inspect periodically and replace if damaged.
- **DO NOT** operate engine with an accumulation of grass, leaves, dirt or other combustible materials in the muffler area.
- **DO NOT** use this engine on any forest covered, brush covered, or grass covered unimproved land unless a spark arrester is installed on the muffler. The arrester must be maintained in effective working order by the operator. In the state of California the above is required by law (Section 4442 of the California Public Resources Code). Other states may have similar laws. Federal laws apply on federal land.
- **DO NOT** touch hot muffler, cylinder or fins. Contact may cause burns.
- **DO NOT** run engine with air cleaner or air cleaner cover removed. Engine damage can result.

Be sure to:

- Remove the wire from the spark plug when servicing the engine or equipment to prevent accidental starting. Disconnect the negative wire

from the battery terminal.

- Keep cylinder fins and governor parts free of grass and other debris which can affect engine speed.
- Examine muffler periodically to be sure it is functioning effectively. A worn or leaking muffler should be repaired or replaced as necessary.
- Use fresh gasoline. Old fuel can gum carburetor and cause poor performance.
- Check fuel lines and fittings frequently for cracks or leaks. Replace if necessary.

2.10 Safety Sign Explanations

The location of safety signs on this equipment are shown in the illustrations that follow. **These areas require your safety awareness!**

Become familiar with each warning and the machine function related to that area.

Think SAFETY! Work SAFELY!

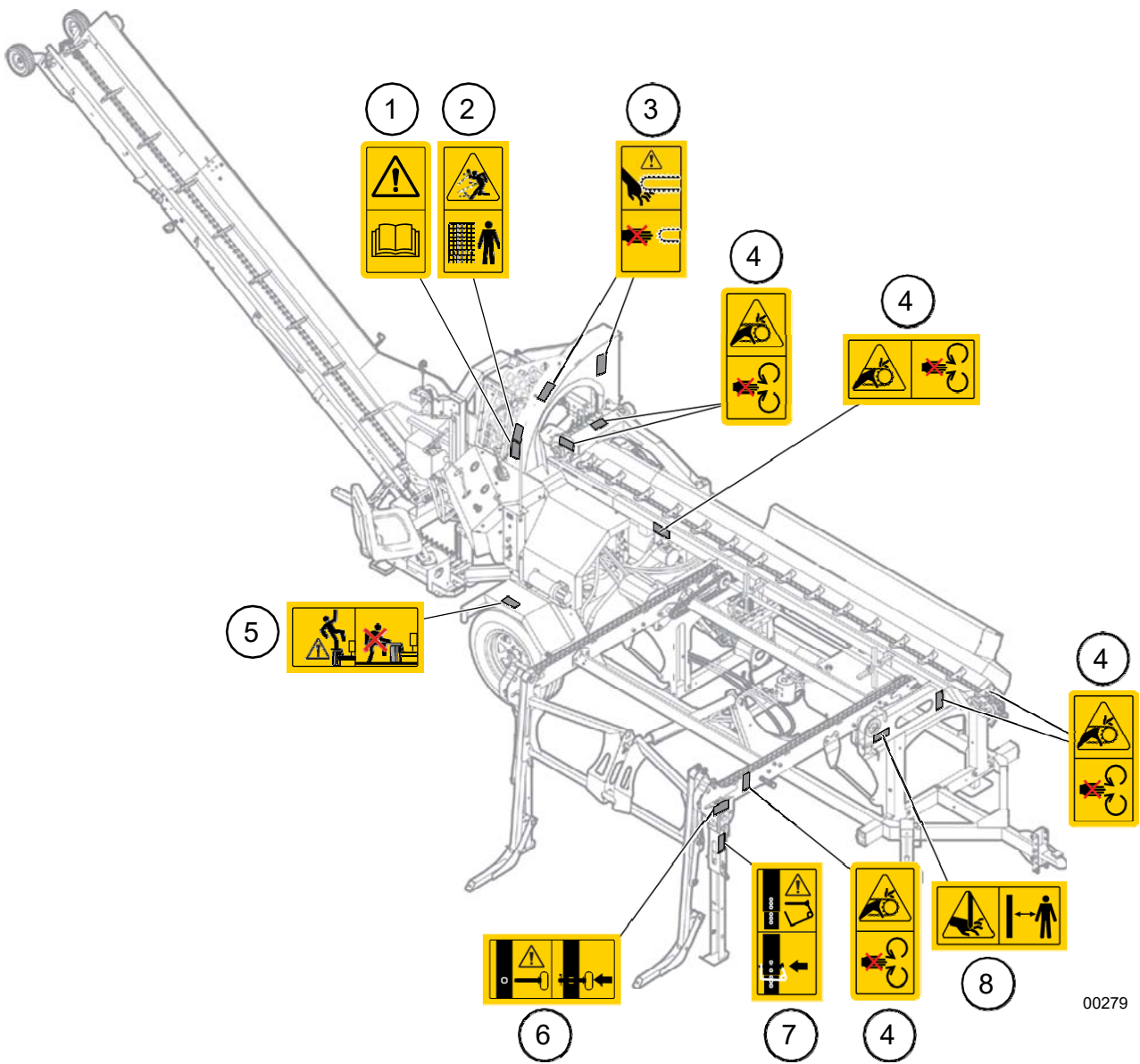

Fig. 2 – Safety Decal Placement

IMPORTANT! If parts are replaced that have safety signs on them, new signs must be applied. Safety signs must always be replaced if they become damaged, are removed, or become illegible.

Safety signs are included in the product decal kit available from your authorized dealer. Decals are not available separately.

1. Warning!



Refer to the operator's manual. Read ALL operating instructions in the manual and learn the meaning of ALL safety signs on the machine.

The best safety feature is an informed operator.

2. Warning!



Risk of wood chips or pieces flying out of this area causing personal injury.

Stay behind protective screen.

3. Warning!



Risk of serious personal injury resulting from contact with chain saw.

Keeps hands clear!

4. Warning!



Risk of hands being pinched or caught in drive chain resulting in serious injury.

Keeps hands clear of this area.

5. Warning!



Risk of falling off machine causing personal injury.

Do not step or stand on this surface. Use provided steps and hand holds.

6. Warning!



Risk of machine moving unexpectedly when support leg pin is removed. Personal injury could result.

Install pin and secure with pin keeper.

7. Warning!



Risk of machine moving unexpectedly when support leg pin is removed. Personal injury could result.

Install pin and secure with safety latch.

8. Warning!



Risk of hands being crushed in this area.

Keep hands clear of all moving parts.

NOTE:
Some equipment
shown is optional.

Safety

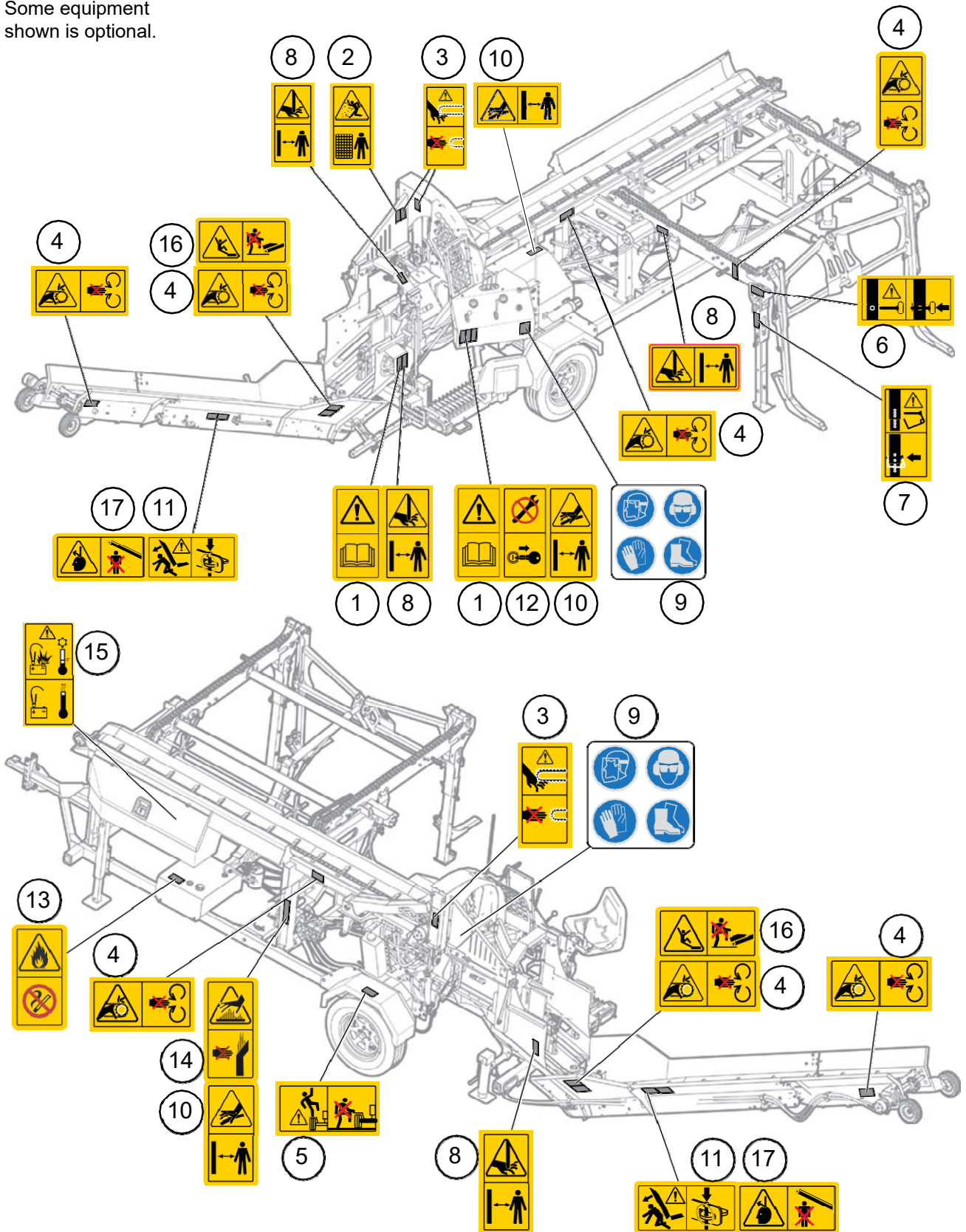

Fig. 3 – Safety Decal Placement

9. Safety Notice



Always wear appropriate Personal Protective Equipment when using this machine. For example:

- A hard hat
- Heavy gloves
- Hearing protection
- Protective shoes with slip resistant soles
- Protective glasses, goggles or face shield

10. Warning!



Risk of high pressure hydraulic fluid piercing exposed skin.

Do not check for leaks with hand or fingers. Serious injury can result.

11. Warning!



Risk of injury from falling equipment.

Install latch during transport.

12. Warning!



Risk of serious injury or death if the engine is not shut off during maintenance procedures.

Shut off the engine and remove the key.

13. Warning!



Risk of explosion.

Do not refuel the machine while smoking or near open flame or sparks. Serious injury can result.

14. Warning!



Risk of burns to exposed skin from hot surfaces.

Stay clear of hot exhaust system.

15. Warning!



Charging a frozen battery can cause it to explode.

Warm the battery to 60 °F (16 °C) before charging.

16. Warning!



Risk of injury from falling off equipment.

Do not climb or step on conveyor.

17. Warning!



Risk of injury from objects falling off conveyor.

Do not walk or stand under the conveyor.

IMPORTANT! If safety signs have been damaged, removed, become illegible or parts replaced without safety signs, new signs must be applied.

2.10.1 Replace Damaged Safety Signs

- Keep safety signs clean and legible at all times. Replace safety signs that are missing or have become illegible.
- Parts replaced that had a safety decal on them must also have the safety sign replaced. Replacement safety signs are available from your authorized distributor, dealer parts department, or the factory.

2.10.2 How to Install Safety Signs

Installation area must be clean and dry. Make sure the surface is free of grease or oil. Ambient temperature must be above 50 °F (10 °C).

 **NOTE:** *Determine exact position before removing the backing paper on the decal.*

1. Remove the smallest portion of the backing paper along one edge. Align the sign with an edge on the machine.
2. Carefully press the exposed sticky backing in place and smooth it out.
3. Slowly peel the backing paper off while carefully smoothing the edge as you work. Work from one end of the decal to the other.

Small air pockets can be pierced with a pin and smoothed out using the piece of sign backing paper.

3. Familiarization

The FP-500H Wood Processor is designed to process cut logs into split firewood. Logs are loaded onto the live deck and moved onto a conveyor where they are fed into the saw. The saw cuts the logs to length and the wood blocks fall into the splitting chamber. The split wood is moved away from the machine on a conveyor (if equipped).

Power to drive the machine is provided through the gas engine and hydraulic pump.

3.1 To the New Operator or Owner

It is the responsibility of the owner or operator to read this manual and to train all other operators before they start working with the machine. Follow all safety instructions. Untrained operators are not qualified to use the machine.

Many features incorporated into this machine are the result of suggestions made by customers. Read this manual carefully to learn how to use the wood processor safely. Following the instructions in this manual along with a good maintenance program can provide many years of trouble-free service.

IMPORTANT! Make sure all operators understand how to put the machine in a safe service position before servicing or repairing. See *Safe Condition on page 9.*

3.2 Operator Orientation

IMPORTANT! When describing controls, the directions for left-hand, right-hand, backward and forward as mentioned throughout this manual, are determined when standing at the operator controls facing the direction of forward machine travel.

3.3 Job Site Familiarization

It is the responsibility of the operator to be thoroughly familiar with the work site prior to starting. Prevent the chance or possibility of problems or accidents by avoiding unsafe situations.

Some items operators should check include, but are not limited to:

1. Avoid close or cramped work spaces. Be sure there is sufficient space and clearance for the machine.
2. Position the machine so prevailing winds blow engine exhaust fumes and chain saw chips away from operator's station.
3. Choose flat and level ground and make sure the machine is level before operating.
4. Avoid muddy or soft ground as the jacks will sink in. If unavoidable, use boards or plates to increase the surface area of the jack feet.

3.1 Machine Components

- 1. Integrated Conveyor (optional)
- 2. Splitting Wedge Assembly
- 3. Block Dropper
- 4. Chain Saw
- 5. Safety Whip
- 6. Infeed Conveyor
- 7. Infeed Conveyor Chain
- 8. Adjustable Trailer Hitch
- 9. Crank Jack
- 10. Log Lifter Shelf (optional)

- 11. Live Deck Supports
- 12. Hydraulic Oil Reservoir Cover
- 13. Manual Tube
- 14. Operator Control Panel
- 15. Operator Seat Accessory
- 16. Crank Jack
- 17. Conveyor Hydraulic Control Valve (optional)
- 18. Live Deck
- 19. Block Dropper and Log Stop Guide
- 20. Crank Jack
- 21. Axle – Full Flex; 4000 lb; Electric Brakes
- 22. Tires – ST205/75R15 LRD
- 23. Chain Saw Oil Reservoir
- 24. Top Roller Assembly
- 25. Engine – Kohler CH752
- 26. Fuel tank
- 27. Crank Jack
- 28. Battery
- 29. Tool Box

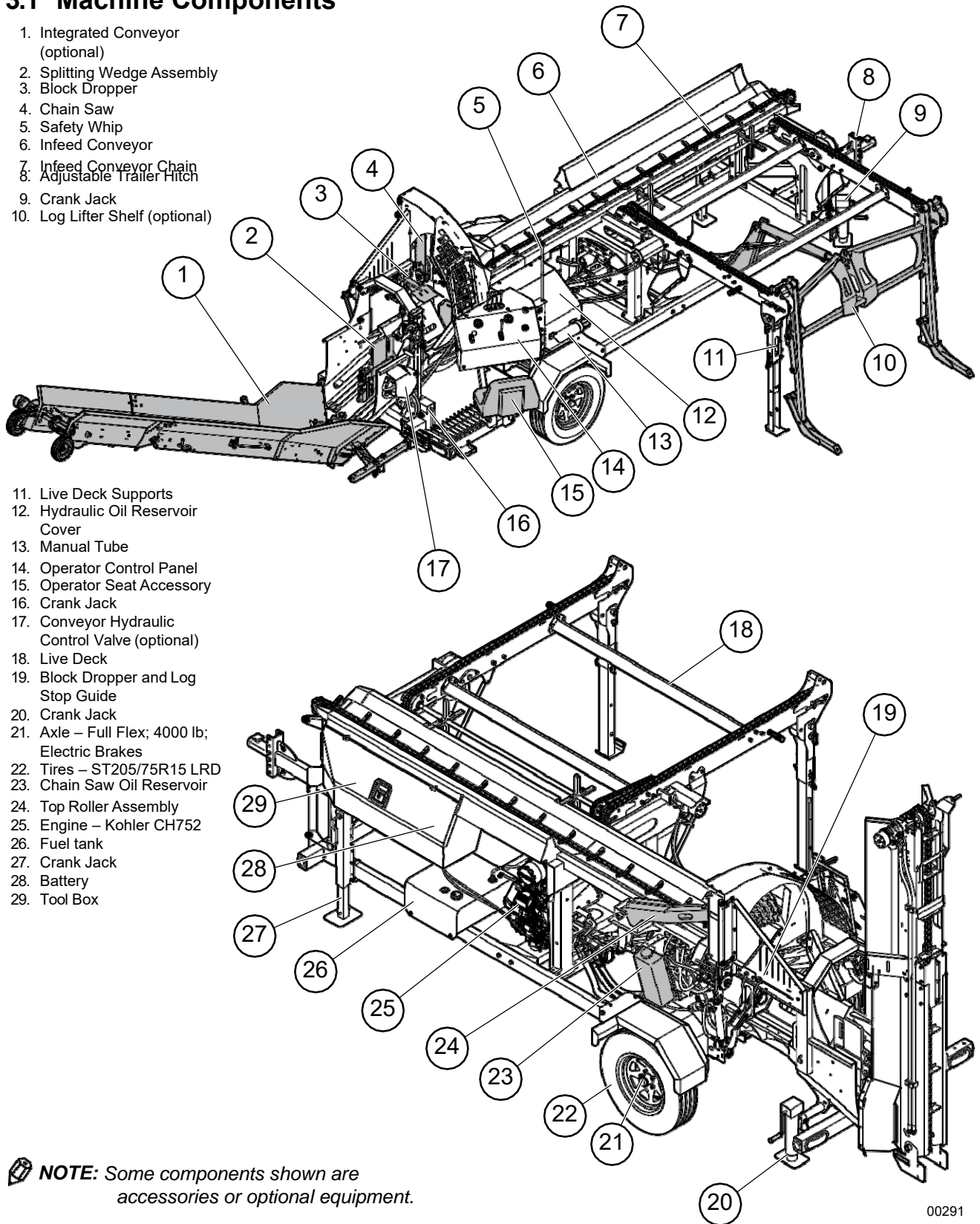

NOTE: Some components shown are accessories or optional equipment.

00291

Fig. 5 – Components

3.4 Engine Controls

Before starting to work, all operators should familiarize themselves with the location and function of controls.

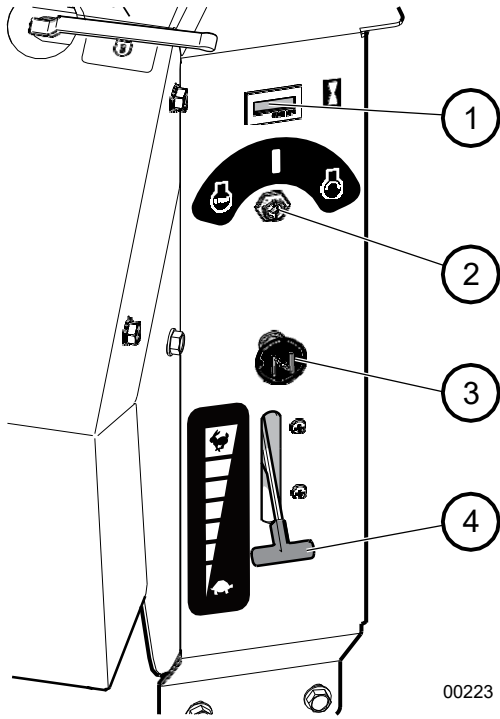

Fig. 4—Engine Controls

- 1. Hour Meter
- 2. Ignition Switch
- 3. Choke Control
- 4. Engine Throttle

1. Hour Meter

The hour meter keeps track of the engine operating hours. Use the hour meter as an indicator for service intervals.

NOTE: The hour meter starts when the ignition switch is turned on. Do not leave the key switch on if the engine is stopped. A false engine hour reading can occur.

2. Ignition Switch

This key-operated switch controls the electric power to the engine.



STOP – Turn key fully counter-clockwise to stop the electrical system power and turn the engine off.



ON – Turn clockwise to the on (run) position at the detent. This is the position where the engine operates.



START – Turn fully clockwise to engage the starter solenoid and start the engine. Release the key when the engine starts and it spring-returns to the center *on* position.

3. Choke Control

This push/pull knob controls the position of the choke.

- Pull the knob out (close the choke) to start a cold engine.
- Push the knob in (open the choke) as the engine warms.

Always push the knob fully in when operating the machine. Refer to the engine manufacturer's manual for complete starting details.

4. Engine Throttle

This lever controls the engine speed.

- Pull the lever up to increase engine speed and push down to decrease it.

3.2 Hydraulic Controls

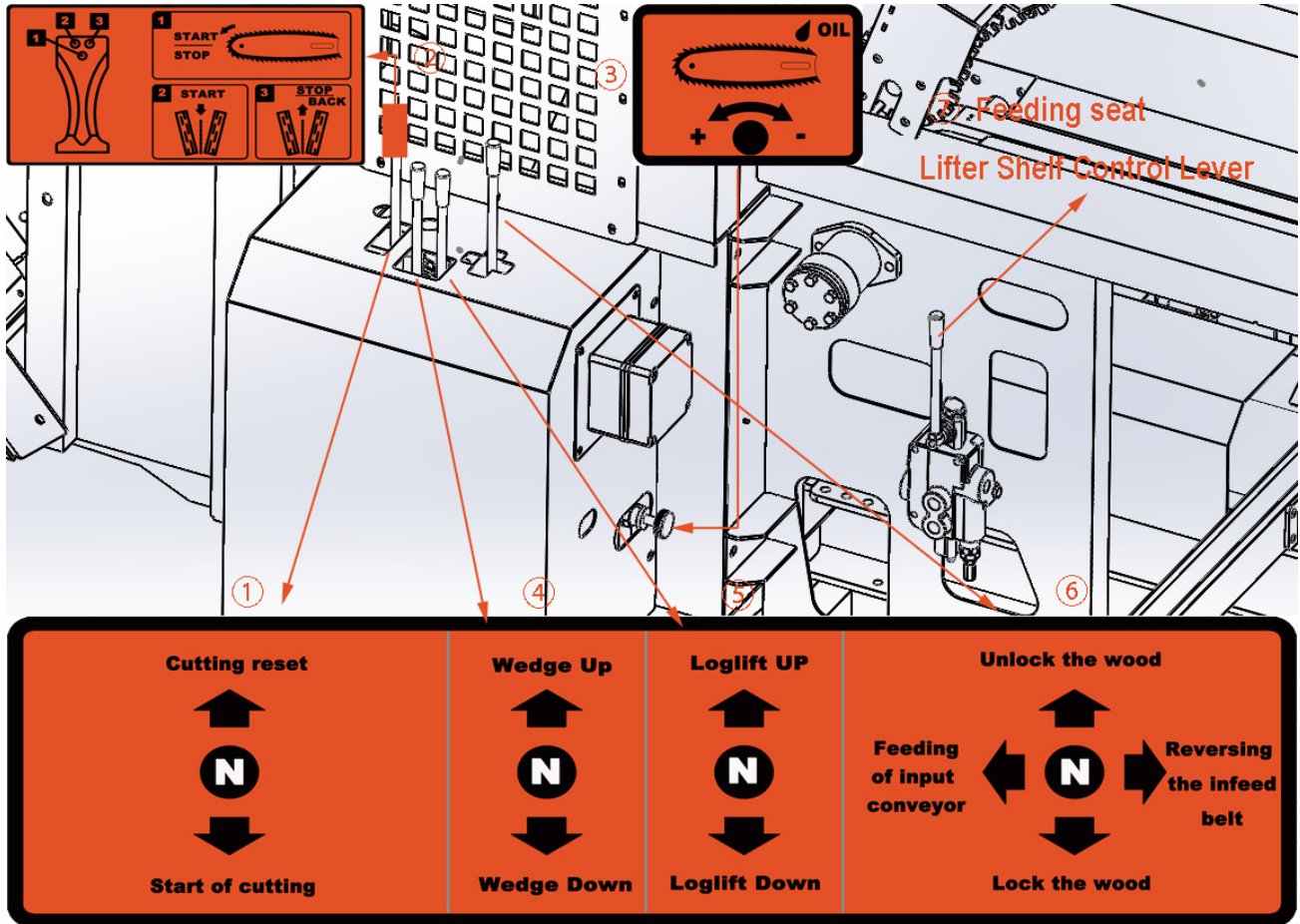

4. Machine Set-up

4.1 Positioning Machine at Site

! CAUTION!

Park the machine so prevailing winds blow exhaust gases / fumes away from the operator.

W006

Select a work site outside or in a well-ventilated area. Make sure the ground is firm and level.

IMPORTANT! Always park the wood processor at the work site on solid, level ground. Use the jack legs to take weight off tires and keep machine stable.

- Park the wood processor so log loading equipment has easy access to the live deck, and split wood can be carried from the conveyor.
- Plan for the clean up and removal of wood chips and sawdust.

! WARNING!

Never use the Trailer Breakaway Switch as a parking brake. The switch is there to safely stop the trailer in the event it becomes accidentally disconnected from the tow vehicle.

Using it as a parking brake when un-hooked drains the machine's battery and would then cause it to be ineffective in an emergency. Once the battery charge depletes, the brakes release and the trailer could move unexpectedly.

W042

- Use the bubble level on the front of the trailer frame as a guide to level the machine.

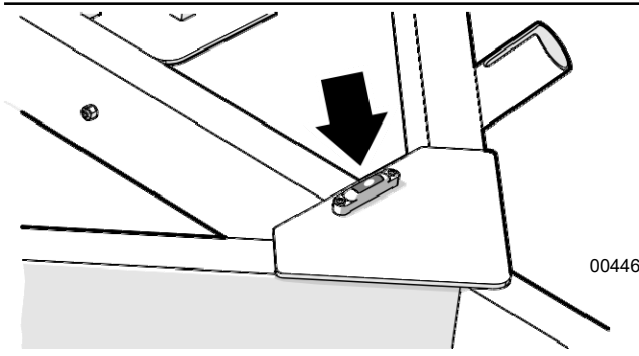

00446

Fig. 7 – Bubble Level on Frame

Procedure

1. Block or chock the wheels so the machine cannot roll.
2. Crank the front jack to raise the hitch coupler and unhook the tow vehicle from the wood processor.

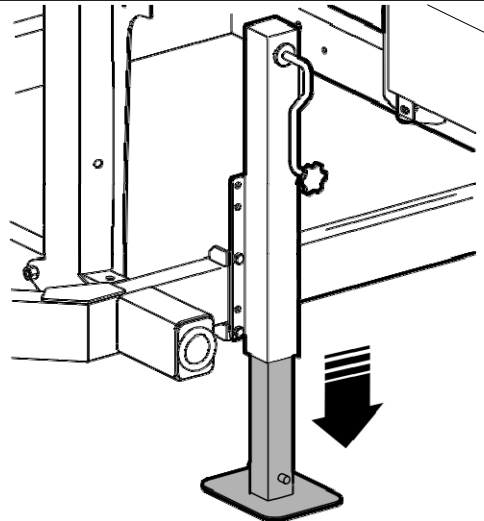

00353

Fig. 8 – Front Crank Jack

3. Disconnect safety chains, breakaway device cable, and wire harness. Move the tow vehicle out of the way.
4. Pull out the snap lock pins from the three crank jacks, rotate them around vertical, and reinsert the pin.

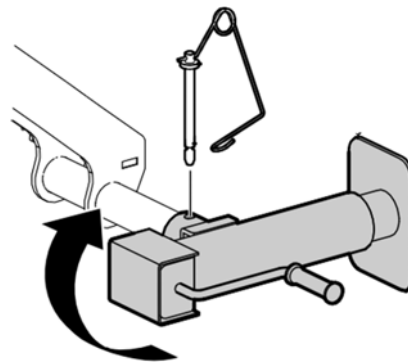

00352

Fig. 9 – Crank Jack

5. Crank the jacks until all jack feet are firmly into the ground, ideally so the weight of the machine is off the tires.
6. Adjust jacks at the front and back to level the wood processor.

4.2 Lowering Live Deck

The live deck is lowered by hand when not equipped with the Log Lifter option.

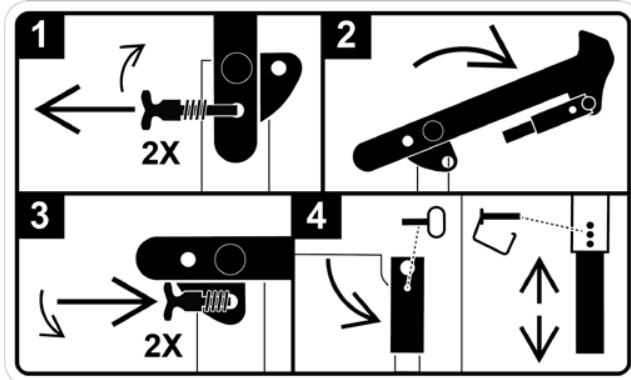

NOTE: Live deck folding force is less than 50 lb (23 kg).

NOTE: If equipped with the Log Lifter Shelf option, the deck is raised and lowered using hydraulic power. See Lowering Live Deck with Log Lifter on page 28.

Procedure:

1. Pull and lock out pins on both sides of the live deck.

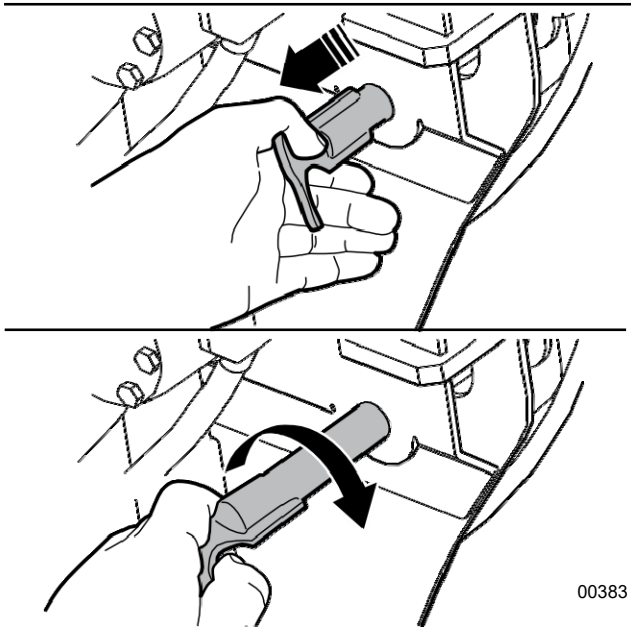

Fig. 10 – Live Deck Locking Pins

2. Pull the live deck down using the handles on the sides.

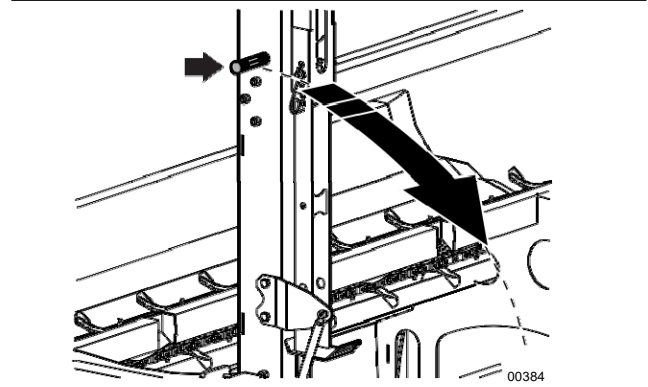

Fig. 11 – Live Deck Handles

3. Reinsert the deck pins to lock it in position.

IMPORTANT! The live deck locking pins must be pinned in place to prevent the live deck from moving during operation.

Support Legs

4. Remove the hitch pins and swing both support legs under the live deck. Reinsert the hitch pins.

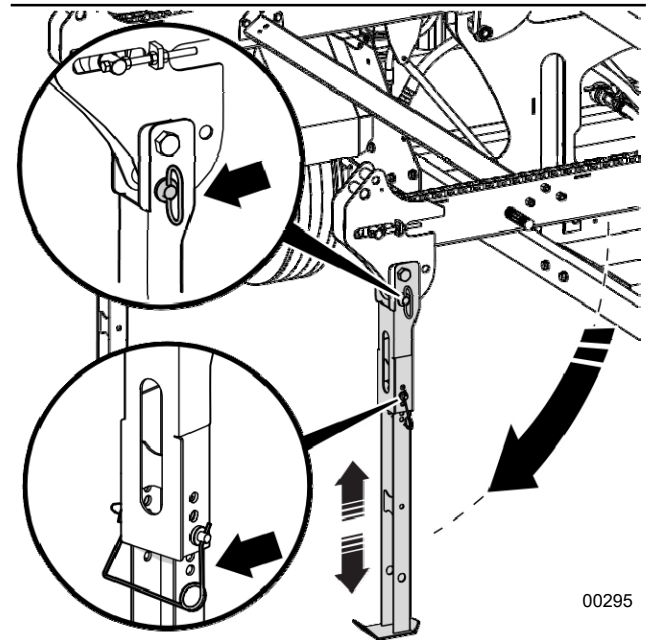

Fig. 12 – Live Deck Support Legs

5. Remove the snap lock pins and adjust leg height so the deck is properly supported. Try to get the deck as level as possible. Reinsert the pin.

IMPORTANT! The live deck supports must be pinned in place to brace the deck during operation.

4.3 Lowering Live Deck with Log Lifter

If equipped with the log lifter shelf option, the live deck is lowered with the log lifter cylinder. A decal on the side of the live deck explains the steps.

- Make sure the machine is completely setup for operation.
- Start the engine. Leave the throttle setting at idle.

IMPORTANT! Leave the engine throttle at idle speed for better control.

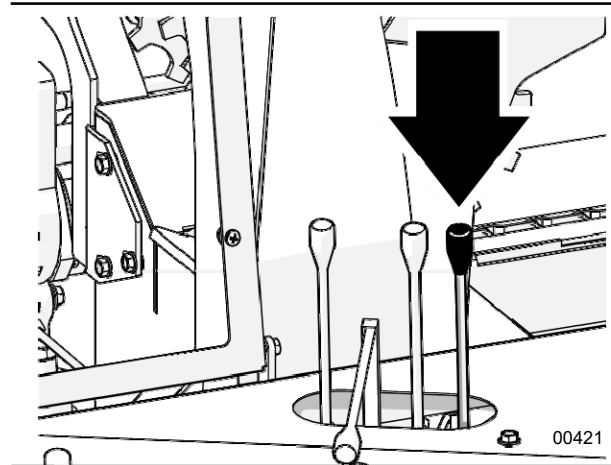

Fig. 14 – Log Lifter Shelf Control Valve Lever

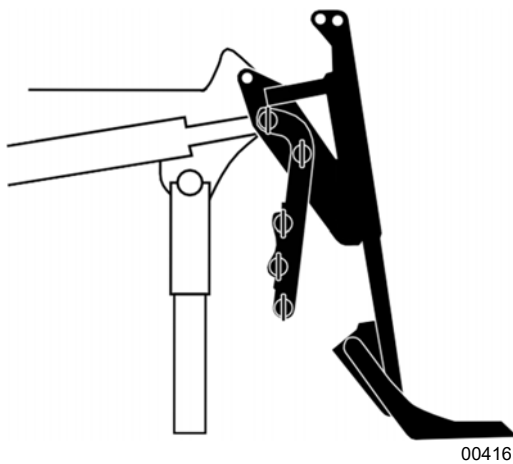
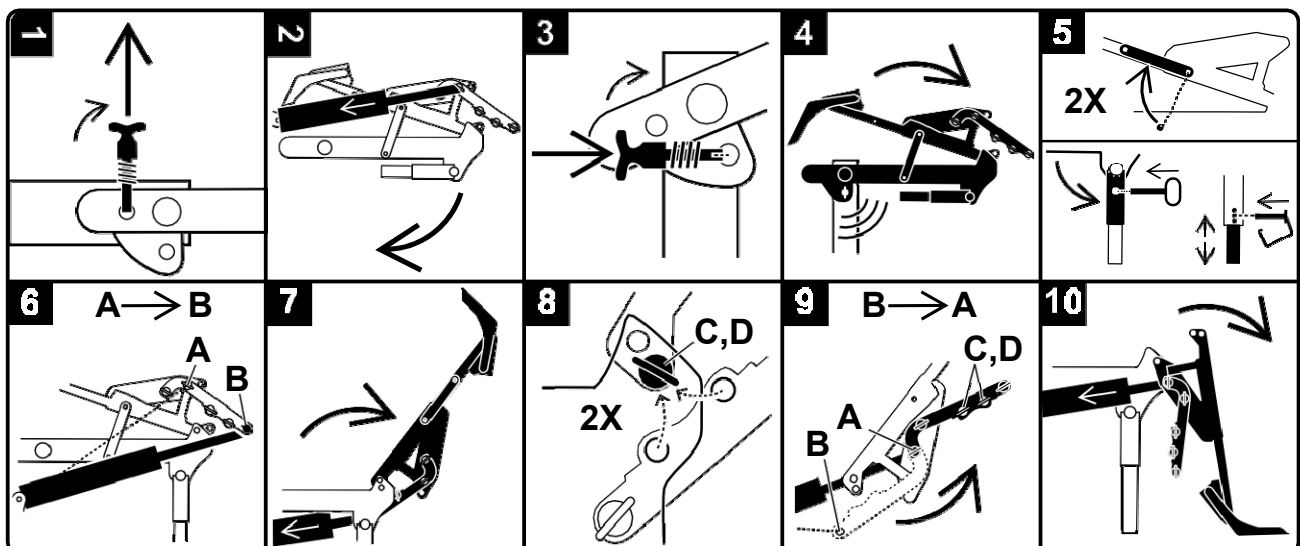

Fig. 13 – Log Lifter Shelf Option



Procedure:

1. Pull and lock out pins on both sides of the live deck.

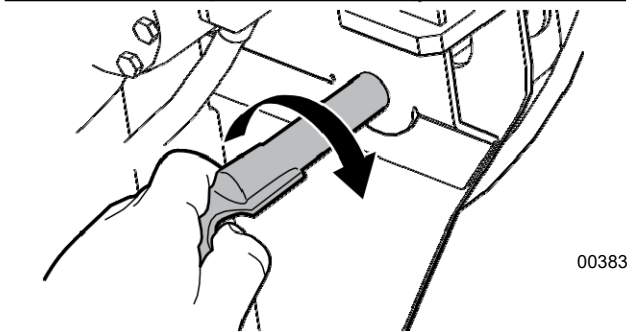
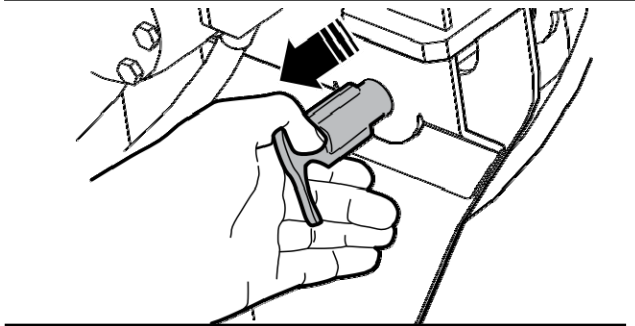

Fig. 15 – Live Deck Locking Pins

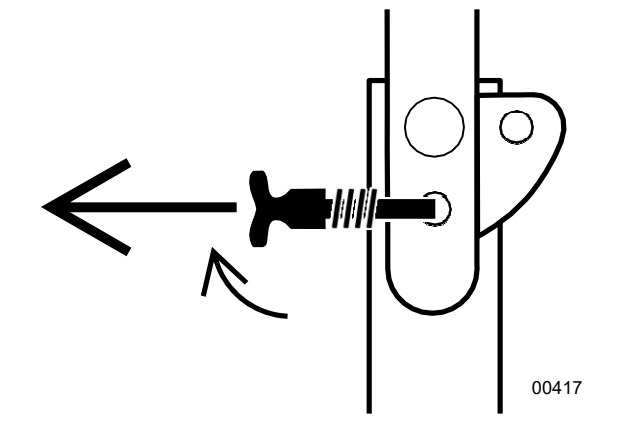

Fig. 16 – Pull and lock out Pins on Both Sides

2. Push the control valve lever forward (retract the cylinder) to begin lowering the deck.
3. Lower the deck over slowly. Before the deck approaches horizontal, pull out and unlock each pin so they retract into the holes. When the deck reaches horizontal, the pins will snap into place to lock the deck.

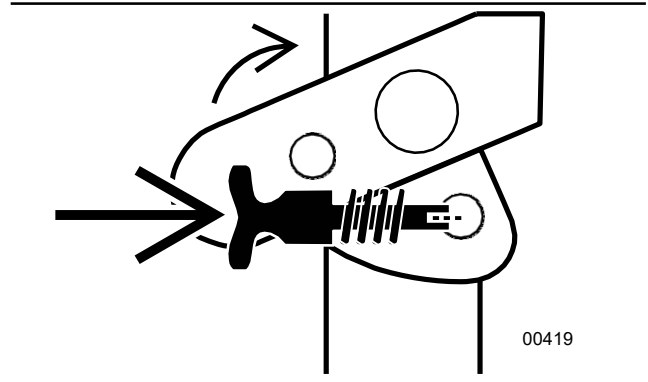

Fig. 17 – Release Locking Pins

4. Listen for the sound of the pins locking into place as the deck is lowered to horizontal. Make sure each pin retracts fully into the hole.

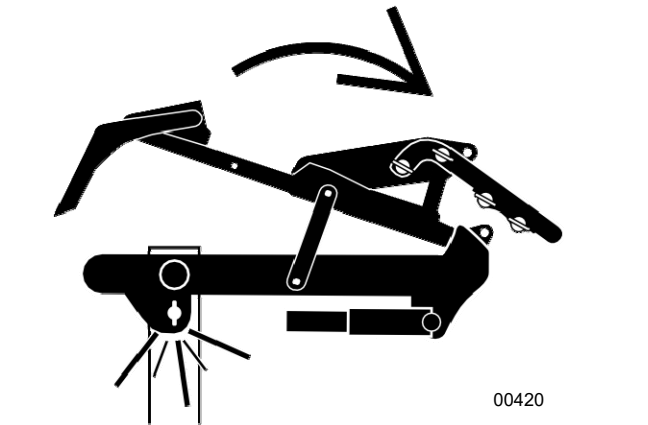

Fig. 18 – Listen for pins locking in place

5. Pin both lifting arm lock straps in their storage position on the log lifter frame.

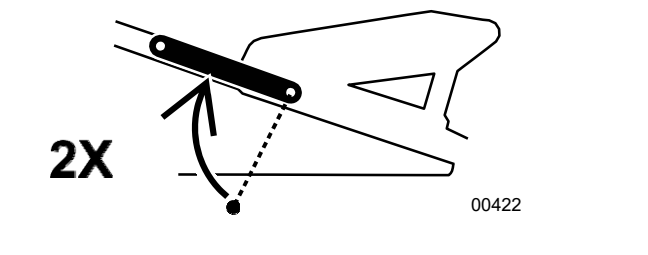

Fig. 19 – Lifting Arm Lock Straps

6. Remove the hitch pins and swing both support legs under the live deck. Reinsert the hitch pins.
7. Remove the snap lock pins and adjust leg height so the deck is properly supported. Try to get the deck as level as possible. Reinsert the pin.

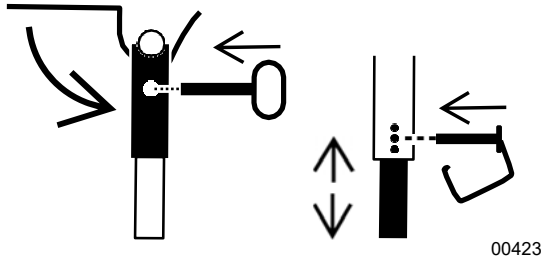

Fig. 20 – Set up Support Legs under the Live Deck

IMPORTANT! The support legs must be in place with hitch pins installed during operation at all times to support the deck.

8. Unpin the end of the log lifter cylinder and move it from position A on the bracket to position B. Reinsert the lynch pin.

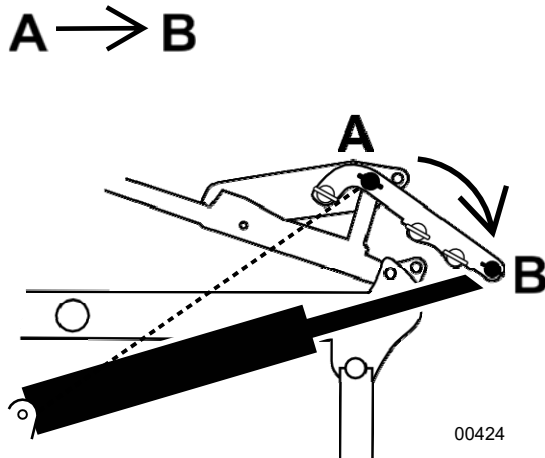

Fig. 21 – Move Cylinder Rod

9. Retract the log lifter cylinder so that the log lifter assembly rolls over past vertical.
10. Roll the lifter assembly over until the holes in the base of the lifter arms line up with the holes in the live deck support.

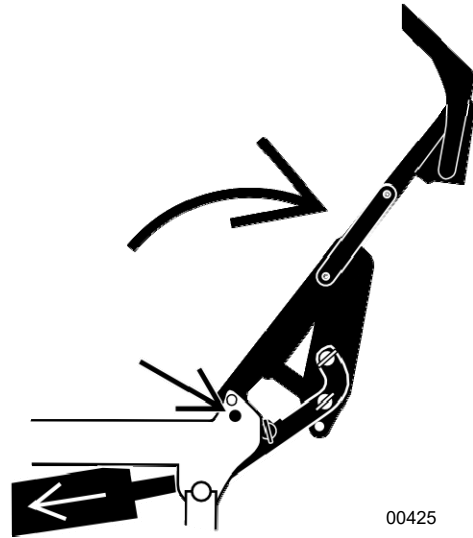

Fig. 22 – Line up Holes in the Live Deck

11. Remove the two pins (C and D) stored on the bracket and insert them into the holes in the live deck. These pins support the log lifter so that the cylinder can be disconnected.

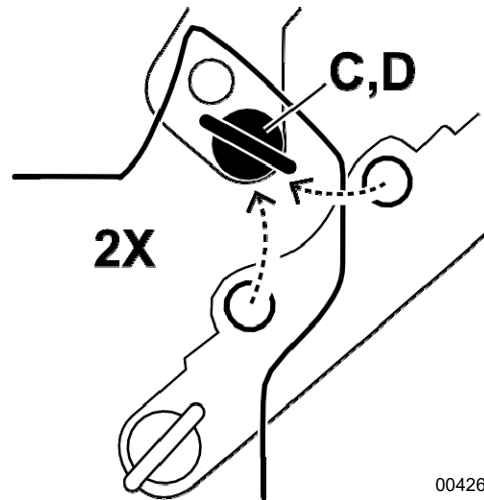
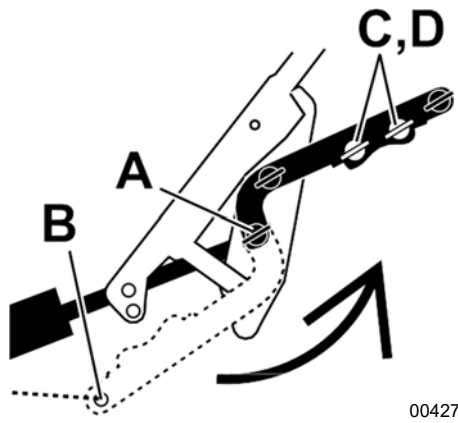

Fig. 23 – Install Pins C and D

12. Unpin the cylinder rod and reposition it back at position A.

B → A



00427

Fig. 24 – Relocate Cylinder Rod

13. Extend the cylinder slightly to take the weight off pins C and D, then remove them. Place them back in their storage position in the bracket.
14. Retract the log lifter cylinder again so the assembly fully lowers. The log lifter is now ready for work.

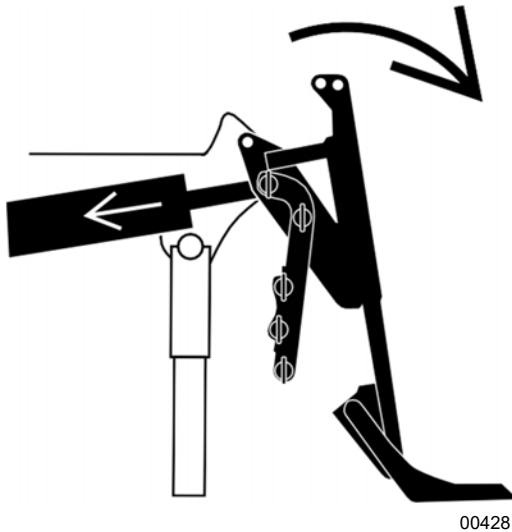

00428

Fig. 25 – Retract the Log Lifter Cylinder

4.4 Raising Live Deck with Log Lifter

To raise the live deck with the log lifter, reverse the above procedure.

4.5 Block Dropper

- The block dropper is mounted on the back of the splitting hopper. When the saw cuts the end of the log off, the block dropper helps it fall squarely into the hopper, preventing jams.

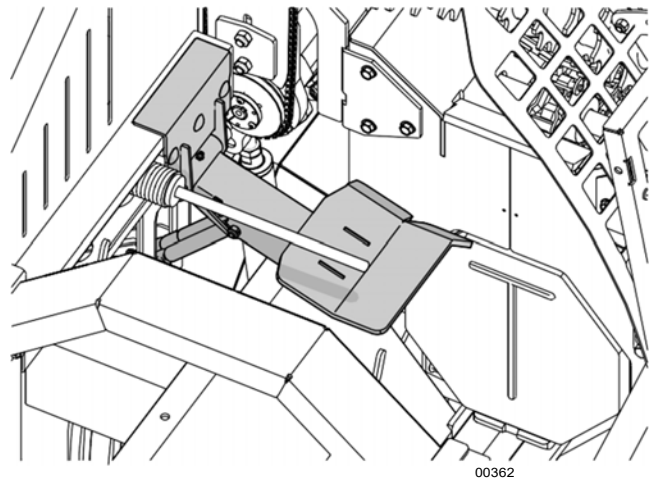

00362

Fig. 26 – Block Dropper

- The block dropper (1) works in conjunction with the Log Stop guide (2).

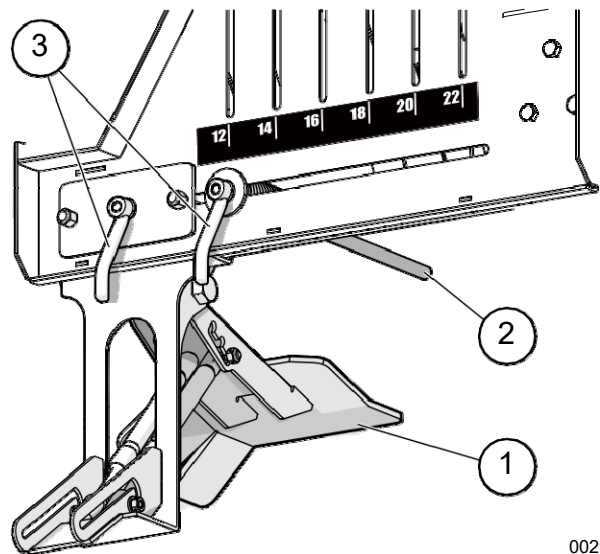

00292

Fig. 27 – Block Dropper and Log Stop Guide

- Block dropper
- Log stop guide
- Lock Handles

4.5.1 Adjust Block Dropper

Set the block dropper for typical log size. The gas struts can be adjusted together or independent of each other.

If the log does not fall squarely into the splitting hopper, adjust as required:

If the block dropper is not required altogether, retract it out of the way. Lift and slide both base ends of the gas struts down the slot on the support (2).

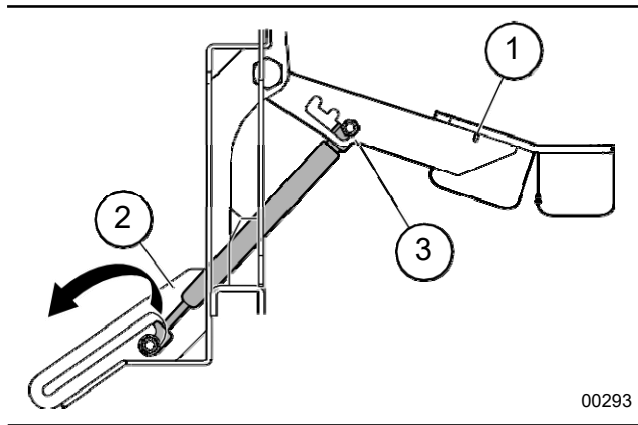

00293

Fig. 28 – Block Dropper Adjustment

1. Block Dropper Arm
2. Base Support
3. Block Weight Adjustment Positions

NOTE: Gas struts can be adjusted or moved independent of each other to match block weight.

4.6 Log Stop Guide

Position the log stop guide for desired firewood length and consistent saw cuts.

- Turn the lock handle counter-clockwise to loosen the guide. Move it into position, then turn the handle back clockwise to tighten it.

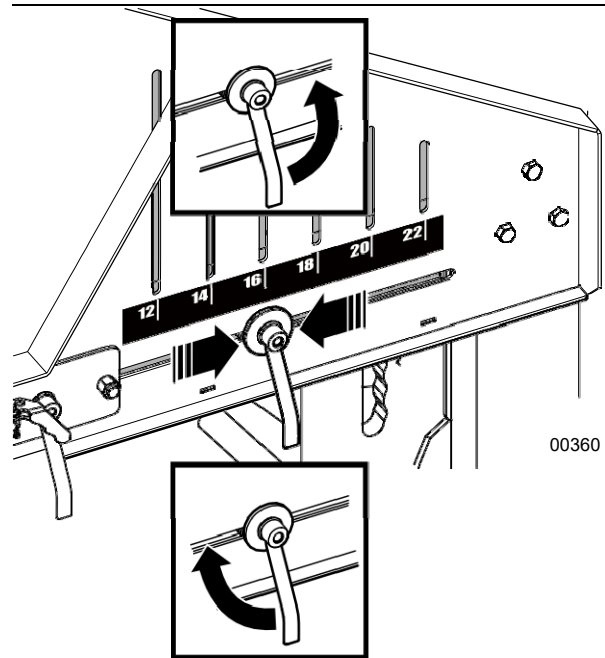

00360

Fig. 29 – Log Stop Guide Lock Handle

4.9 Making the Work Area Safe

When processing logs with this machine, create a safe work area around the entire operation. The work area should be split up into the following zones, based on the level of safety awareness:

Safe Zone – This is the area outside the work area perimeter for bystanders or anyone not directly involved with the work. The Safe Zone has minimal potential hazards.

Work Zone – Workers helping the operator wearing the appropriate PPE are allowed in this area. The Work Zone is outside of the Danger Zone with limited hazards.

Danger Zone – Only workers are allowed in the Danger Zone and must always make eye contact with the operator before entering. Unauthorized workers or bystanders are not allowed in the Danger Zone due to the hazards present.

Operator Zone – Only the operator should be in the Operator Zone.

Follow these important points to keep bystanders and workers safe from hazards.

- Establish a Safe Zone perimeter around the work area and mark with safety cones. The perimeter should be at least 10 ft (3 m) from any hazard within the work area.
- Never allow workers or bystanders to approach the processor while in operation without first signaling the operator.
- Keep all bystanders in the Safe Zone and never allow them in the Danger or Work zones.
- Always operate the processor controls from the Operator Zone located at the control panel.
- Only the operator can authorize entry into the Danger Zone. The operator must first ensure it is safe to enter.
- Always be aware of coworkers. Make eye contact and have a hand signal scheme worked out.
- Use extreme caution around the material stacks. Stacked logs could roll in unpredictable ways.
- Be aware of split wood stacks. Split wood can tumble off the pile.

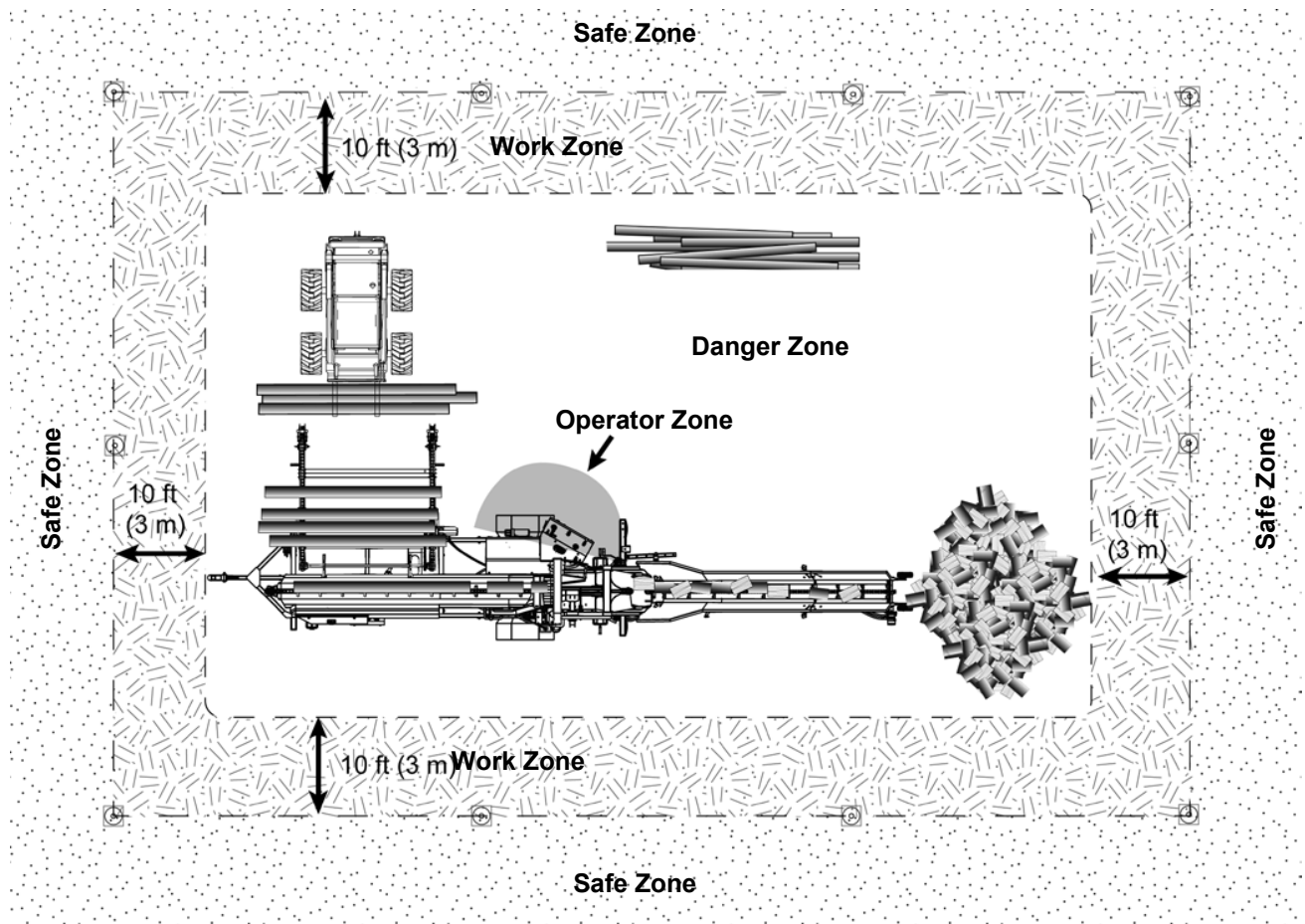

Fig. 32 – Work Area divided into Zones

5. Pre-start Checks

5.1 Pre-Operation Checklist

Efficient and safe operation of the wood processor requires understanding operation and safety precautions outlined in this section.

Follow the pre-operation checklist for personal safety and to keep the machine in good mechanical condition.

Before operating the wood processor, check the following areas:

Pre-operation Checklist	
Check and lubricate the machine per the schedule outlined in the Maintenance Section. See <i>page 53</i> .	
Check the splitting wedge and block. Inspect for damaged or broken components and excessive wear. Lubricate, repair or replace as required.	
Check the saw chain. Look for broken or worn parts. Check the bar guide and chain tightness.	
Inspect the conveyor, infeed conveyor and live deck chains. Tighten chains if necessary. Look for broken or worn parts	
Check and ensure that all covers, guards and shields are in place, secured and functioning as designed.	
Check and tighten all fasteners. Make sure equipment is working and in good repair.	
Check for hydraulic leaks. Tighten fittings or replace components to stop leaks.	
Make sure there is bar oil in the reservoir.	
Check that personal protection equipment including hard hat, safety glasses, safety shoes, safety vest, hearing protection and gloves are available, in good repair, and being used.	
Check that loose fitting clothing or jewelry is not worn and loose, long hair is tied back.	

5.2 Before Starting the Engine



Hearing loss hazard. Prolonged exposure to loud noise may cause permanent hearing loss. Use suitable protection while operating the machine.

W016

The operator has the responsibility of being familiar with and following all operating and safety procedures.

Although this machine is easy to use, each operator should review this section to get familiar with the detailed safety and operating procedures.

1. Make sure the machine is set up correctly. See *Machine Set-up page 26*.
2. Check the engine oil level. See *page 36*.
3. Check the hydraulic oil level. See *page 51*.
4. Check the fuel level. See *page 36*.
5. Check the bar oil level. See *page 37*
6. Review the Safety Rules on *page 10*. Make sure each operator is trained and familiar with the set up and operation of the machine. Review the Controls (see *page 24*).
7. Clear the area of bystanders.

5.3 Fuel Level Check

Check the fuel level daily. A gauge on the top of the tank indicates fuel level. The fuel tank is located on the left-hand side of the machine below the tool box. Avoid running the tank dry.

Starting with a full tank helps to eliminate or reduce operating interruptions for refueling.

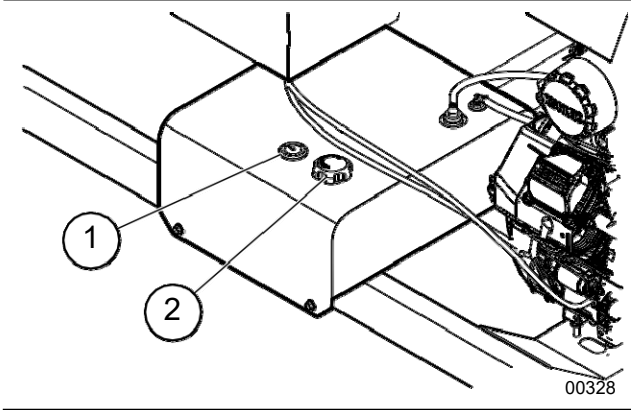

Fig. 33—Fuel Tank

- 1. Fuel Level Gauge
- 2. Fuel tank Cap

5.3.1 Refueling

Fuel tank capacity: 10 US gal (37 L).

WARNING!



Fuel vapors can explode causing injury or death. Do not smoke while refueling. Keep sparks, flames, and hot components away.

W027

Refuel in a well-ventilated area with the engine stopped. If the engine has been running, allow it to cool first. Never refuel the engine inside a building where gasoline fumes can come in contact with flames or sparks.

For fuel specification, see *Engine Fuel* on page 51. Refer to the engine manual for additional information on fuels.

Procedure:

1. Clean the area around fuel tank cap. Fill the tank to 1/2" (12 mm) below bottom of filler neck to provide space for any fuel expansion. **Do not overfill.**
2. Install fuel fill cap securely and wipe up any spilled fuel.

NOTE: To help prevent running low on bar oil, top up reservoir every time fuel is added.

5.4 Engine Oil Level Check

Check engine oil level daily. Check with the engine stopped.

IMPORTANT! Running the engine with a low oil level can cause engine damage that is not covered by warranty.

Procedure:

1. Remove the oil level dipstick and wipe it clean.
2. Fully insert the oil level dipstick, then remove it to check the oil level.
3. If the oil level is low, remove the oil filler cap and add oil until the level is at the FULL mark on the oil level dipstick.
SAE 10W-30 is recommended for general use.
4. Reinstall the oil level dipstick and oil filler cap.

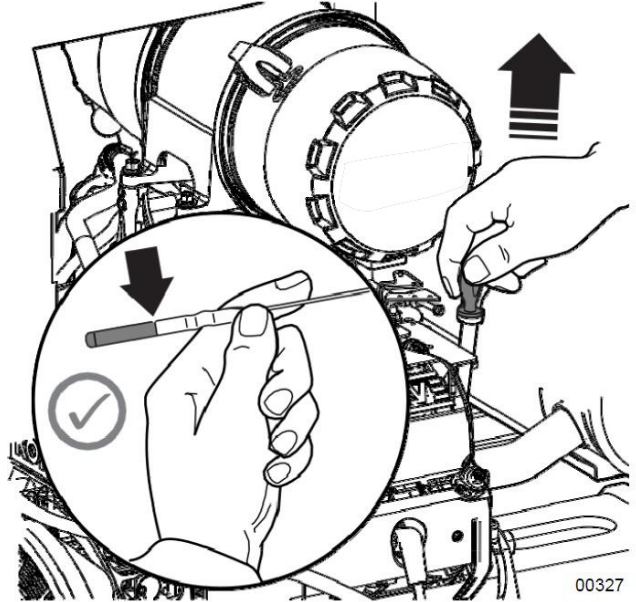

Fig. 34 – Checking Engine Oil Level

- 1. Oil Filler Cap
- 2. Oil Level Dipstick

Refer to the engine owner's manual included in the manual tube for further information on engine oils.

5.5 Hydraulic Oil Level Check

Check hydraulic oil level daily. The hydraulic oil tank sight glass is on the front of the tank. Check level with the engine stopped.

The proper level is when the oil fills the glass window. If the level is not visible in the sight glass, add oil.

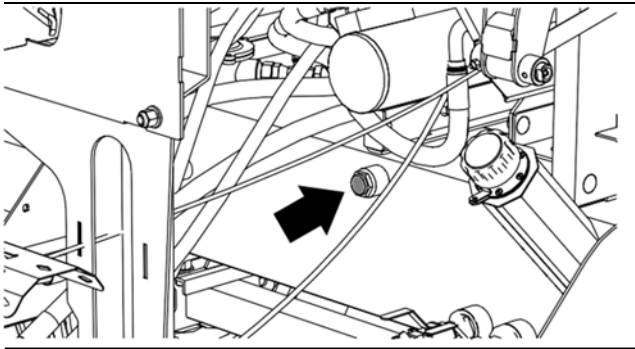

Fig. 35 – Hydraulic Tank Oil Level Check

1. Hydraulic Tank Filler Cap
2. Oil Level Sight Glass

IMPORTANT! Do not operate machine if oil level is not visible in the sight glass. Damage to the pump and other components can occur.

Do not overfill the tank past the sight glass window.

IMPORTANT! Hydraulic oil quality should be inspected every 50 hours. If the oil is dirty or smells burnt, it should be replaced.

IMPORTANT! Be aware of high oil temperatures. Temperatures higher than 180 °F (82 °C) could cause seal damage and degrade oil quality.

5.5.1 Adding Oil to the Tank

Hydraulic oil first choice Dexron III, AW-46 and AW-32 can be as options.

Procedure:

1. Clean the area around filler cap and remove it.
2. Use a clean funnel and add oil until the level just fills the sight glass window.
3. Install filler cap securely. Wipe up any spilled oil.

Check levels after changing filters or servicing hydraulic components.

5.6 Saw rod lubrication flow adjusting

The switch is on the right side of the operating box, clockwise turning to reduce the flow, anti clock-wise to increase the flow.

Your cutting system operates in a challenging environment and depends on sufficient lubrication to minimize wear and extend the life of operation. At start up, allow adequate time for the oil from the reservoir to reach the cutting system.

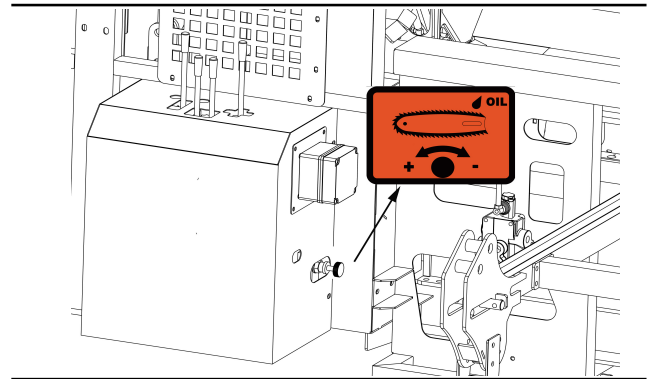

Fig. 36 – Saw rod lubrication adjusting valve

Bar and chain oils provide adequate lubrication to the cutting system when used correctly.

5.7 Saw Chain – Checking

- Check saw chain tension regularly.
- Grasp the chain with a gloved hand at the mid point of the guide bar and pull the chain away from the bar rails. The saw chain should come out of the bar groove about 1/8 in (3 mm).

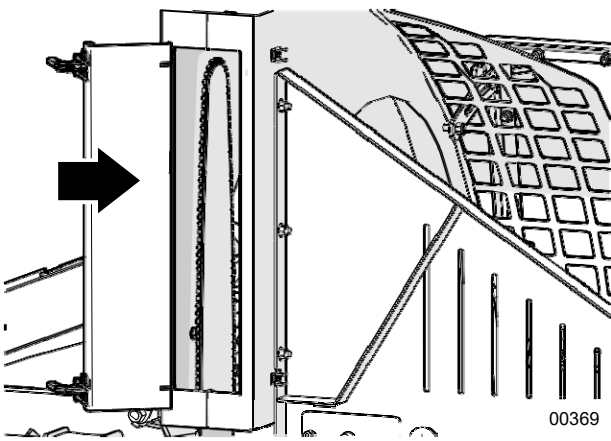

Fig. 37 – Saw Access Door

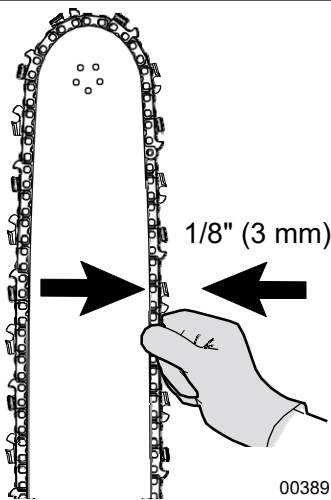



Fig. 38 – Check Saw Chain Tension

- Inspect for broken, cracked, damaged, or missing saw chain components. Inspect loose rivets. If rivet can be turned by hand, it is too loose.
- Inspect for excessive stretch. Stretch is actually wear occurring to the flange of the rivet and the holes in drive links.
- Inspect the chain chassis for abnormal wear patterns, which are indicators of other cutting system issues with the guide bar and drive sprocket.

 **NOTE:** Refer to the Oregon® Mechanical Timber Handbook for additional information on the saw chain and bar. A copy of this manual can be found on the website under Technical Reference.

5.8 Machine Break-In

Although there are no operational restrictions on the wood processor when used for the first time, it is recommended that the following mechanical items be checked:

For new saw chain, check tension often during the first 10 minutes of use.

Consider transporting new and newly sharpened saw chain to and from the job site in a container with lubricant.

1. Lubricate your saw chain prior to use.
2. Increase saw speed gradually over the first 2–4 minutes of running time while cycling the guide bar, until bar oil is observed coming off the tip.
3. Check saw chain tension. Adjust if necessary.

After 1–5 hours of operation:

4. Check all nuts, bolts and other fasteners. Tighten to their specified torque.
5. Check hydraulic system for leaks. Tighten all leaking fittings and replace any leaking components.
6. Check machine fluid levels: Fuel, engine oil, and hydraulic oil reservoir. Top up as required.
7. Check for entangled material. Remove all entangled material before resuming work.

After 20 hours of operation:

8. Repeat Steps 4 through 7 listed above.
9. Check and adjust the tension on all drive chains. Chains may stretch slightly as they wear in. See page 62.
10. Go to the normal servicing and maintenance schedule as defined in the Maintenance Section. See page 52.

6. Operation

The FP-500H wood processor handles logs and splits wood in a very efficient manner. Controls are positioned on the panel so they can be used at the same time.

Logs can be cycled through quickly:

1. Push the handle ⑥ to left to delivery the log to setting position, then pull down the handle to lock the log ready for sawing.
2. Press the button 1 to run the chain of the saw meanwhile pull down the handle ① for sawing.
3. Press the button 2 to start the splitting.

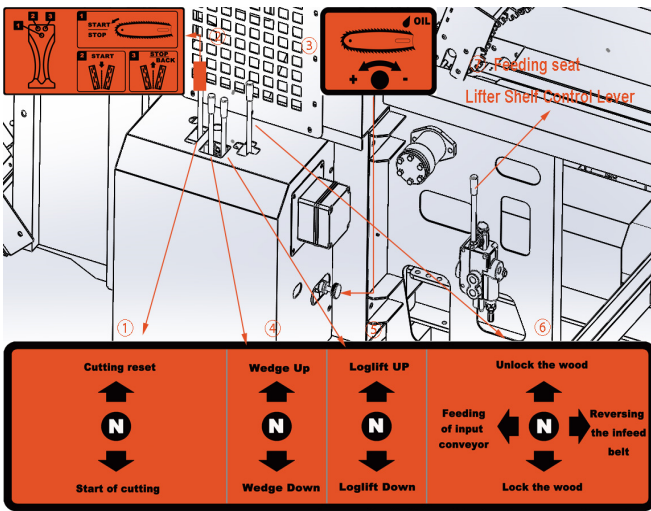

Fig. 39 – Infeed Conveyor, Saw Cut, and Splitter Controls

NOTE: If the firewood is less than 24", it is not necessary to push the block completely through the splitting wedge. Split it partially, then let the next block following finish it.

For the best efficiency, advance the log for the next cut as the splitter is retracting.

6.1 Starting the Engine

Refer to the engine manufacturer owner's manual for further information.

- The wood processor should be set up to work, all pre-start checks completed and otherwise ready to operate.
- Check all hydraulic control levers are in neutral (out of detent).

Procedure:

1. Pull out (close) the choke (1), if the engine is cold.

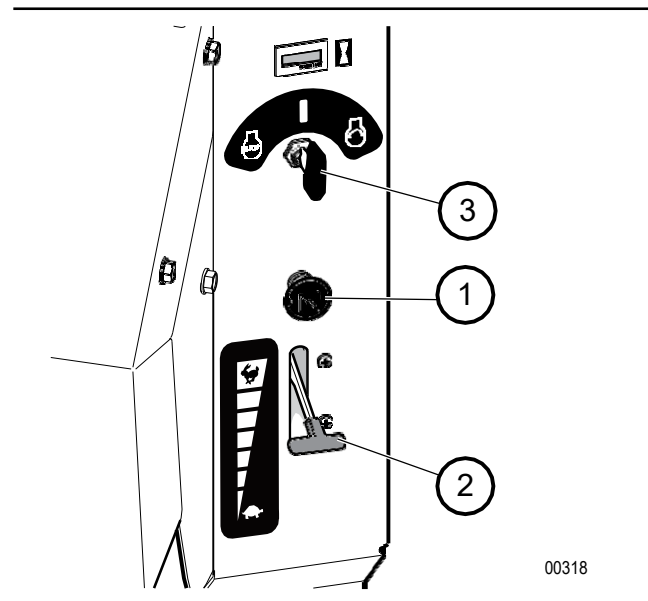

Fig. 40 – Side Console

2. Move the throttle (2) up to 1/4 throttle position.
3. Turn the ignition key (3) clockwise to start the engine. Release the key when the engine starts. The key will return to the run position when released.
4. Idle the engine for a few minutes to allow it to warm up. Gradually push the choke control knob in as the engine warms.
5. Increase throttle setting to maximum. Maximum engine speed is required for smooth operation of hydraulics.

6.1.1 Stopping Procedure

1. Stop cutting and splitting logs. Clear all split wood out. Let hydraulic controls go to their neutral position.
2. Move the throttle to idle position to slow the engine speed and allow it to cool down.
3. Turn off the ignition switch to stop the engine.

6.1.2 Stopping in an Emergency

- Shut off the engine
- Set all hydraulic controls to neutral
- Correct fault situation before restarting engine and resuming work.

6.2 Live Deck

Load logs onto the live deck so the deck chains can drop them into the infeed conveyor trough, one at a time. **Maximum log length is 16 ft (5 m).**

- Push the valve lever forward to feed log onto the infeed conveyor. Pull the lever back to reverse live deck.
- Do not stack logs. Try to keep logs square with the deck rails.
- Always load logs with the bigger end of the log towards the saw.
- Place logs on the live deck so weight is evenly distributed. Try to keep logs parallel to infeed conveyor trough.
- Use the safety whip as a guide when setting logs onto the live deck to avoid interfering with the operator's station.
- Shut down the machine if more than one log drops into the conveyor trough so the second log can be removed. Sometimes reversing the live deck allows the separator tines to grab the log out of the infeed and back onto the live deck.

WARNING!

Do not load logs longer than 16 ft (5 m) onto the live deck. They could fall off the deck and cause a crushing hazard.

W045

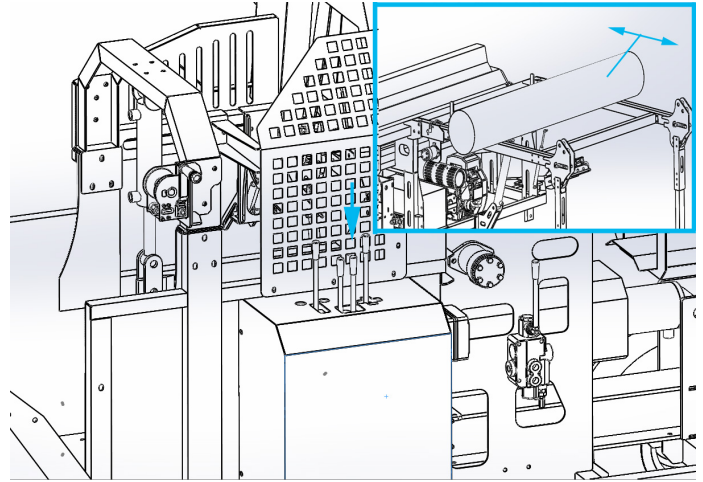



Fig. 41 – Live Deck Control Valve

IMPORTANT! Set heavy logs onto the live deck carefully. Dropping them from a height could damage the deck and supports. Repeated pounding could also drive the support legs into the ground, resulting in an uneven deck.

 **NOTE:** Log minimum length for the live deck is 6 ft (1.8 m). If logs are shorter than that, load them from the back.

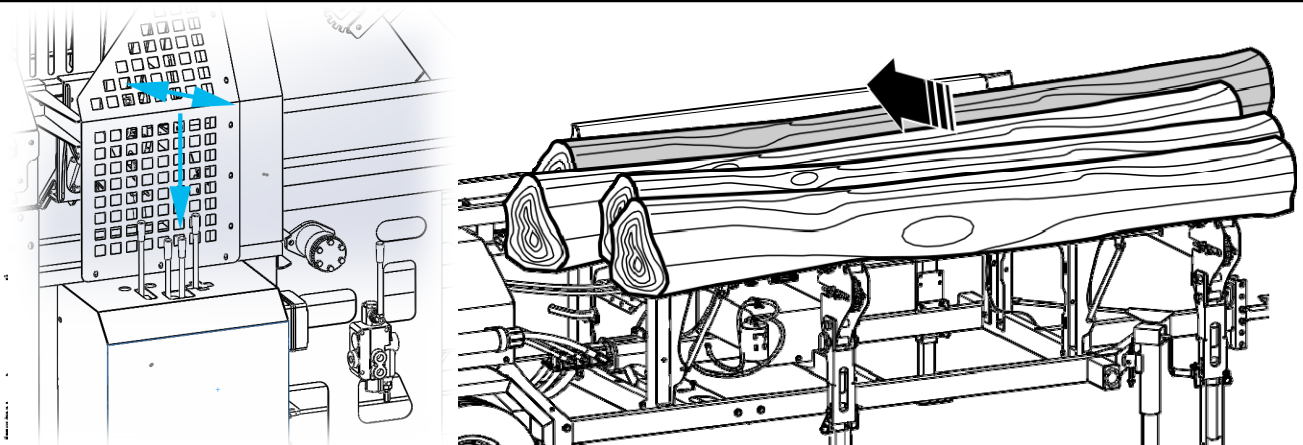



Fig. 58 – Safety Whip

6.6 Log Lifter (optional)

The log lifter option provides a method for loading logs onto the live deck from ground level.

If equipped, an additional control valve lever is provided on the far right-hand side of the main control valve.

- Push the lever forward to lower the live deck.
- Pull the lever back to raise the deck.

 **NOTE:** The log lifter may be used as a deck extension. Raise it to horizontal to hold extra logs.

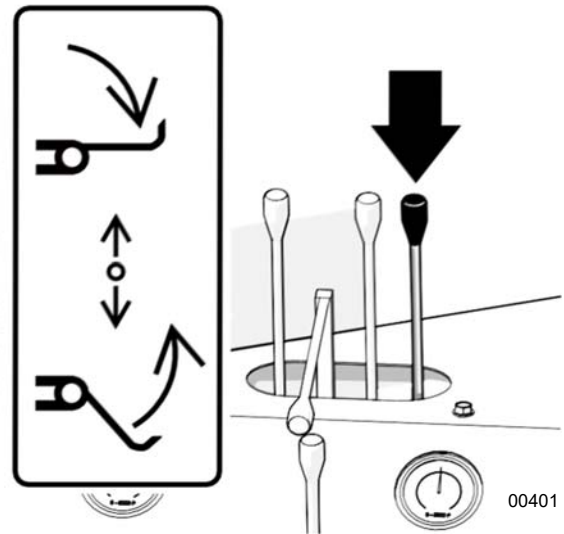
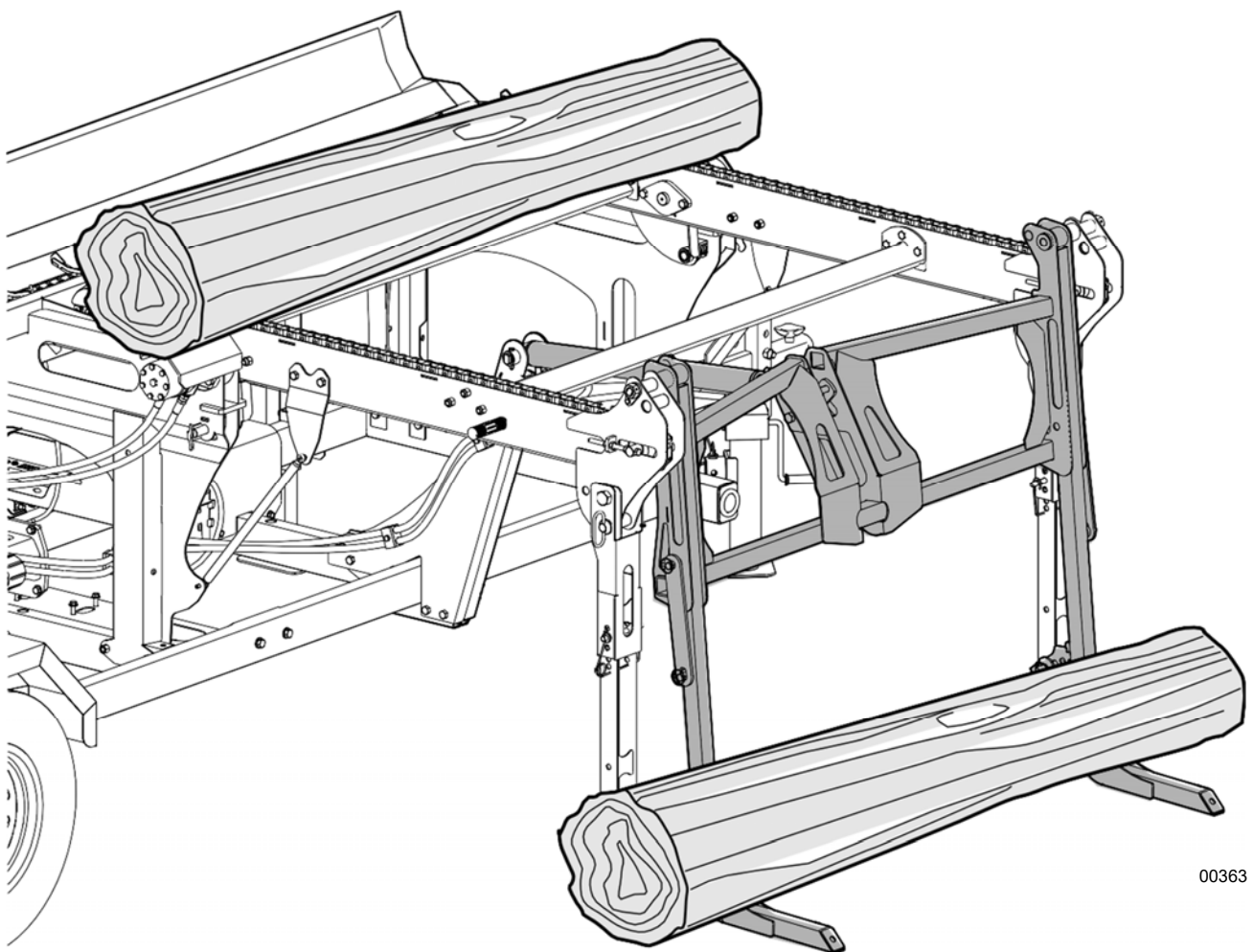

Fig. 59 – Log Lifter Control Valve Lever



00363

Fig. 60 – Log Lifter

6.3 Infeed Conveyor

The infeed conveyor moves the log to the saw.

IMPORTANT! Before advancing the log, always make sure saw is raised FULLY. Running the log into the saw can damage it.

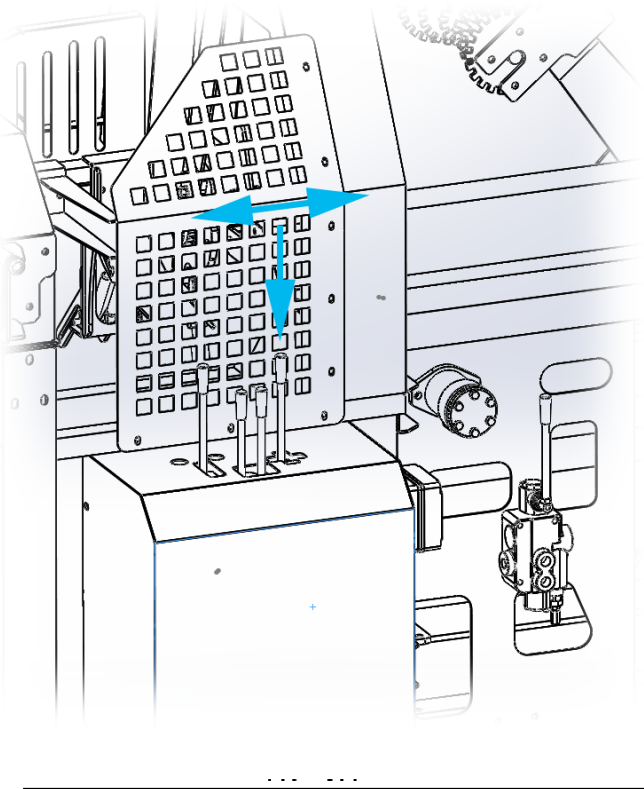

Fig. 42 – Infeed Conveyor Control Valve

- Push the control valve handle down to advance the log to the log stop guide.
- If reversing the log is required, push the lever upward away from the operator.

NOTE: The top roller keeps slight down pressure on the log and follows its contour as it advances on the infeed conveyor.

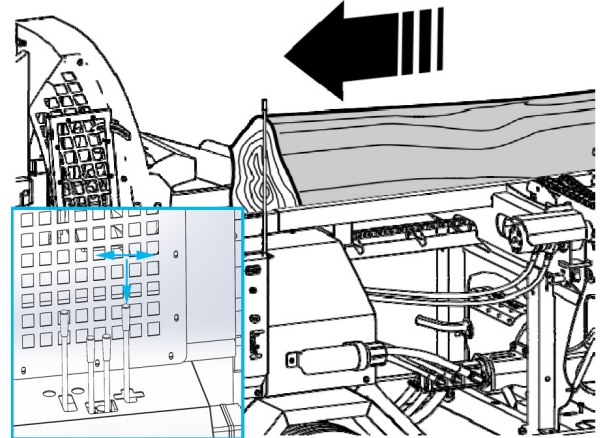

Fig. 43 – Advance Log

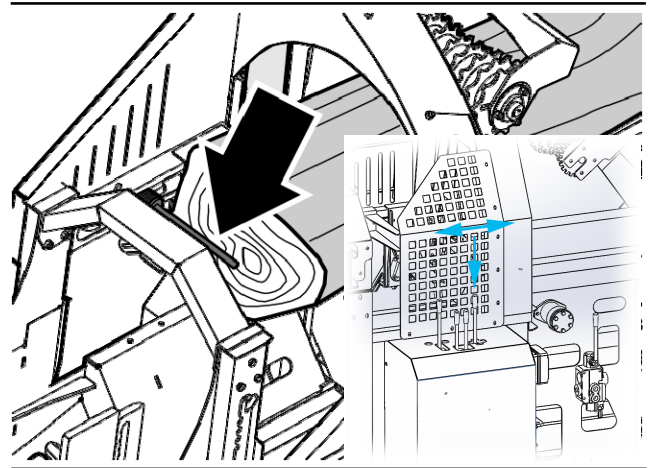

Fig. 44 – Log Stop Guide

6.3.1 Hookaroon

Use the hookaroon when repositioning logs. Use it to extend reach and keeps hands away from machinery.

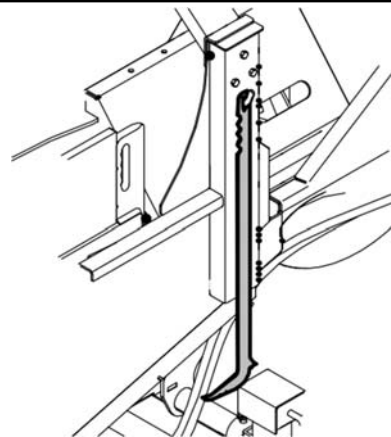

Fig. 45 – Hookaroon

00294

6.3.2 Starting a New Log

When starting a new log, it is often necessary to raise the top roller clamp up out of the way and lock it there. Then the log can be moved ahead and the clamp can be dropped back down on top of it afterward.

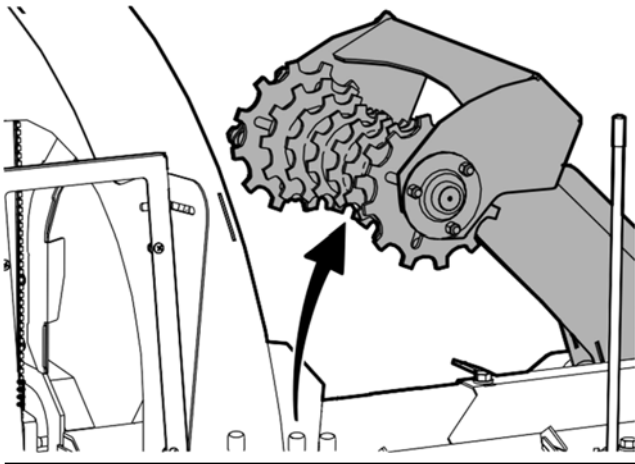

Fig. 46 – Top Roller Clear for Next Log

Raise Top Roller

- Push the saw control lever forward and hold in the *raise* position to raise the top roller clamp.

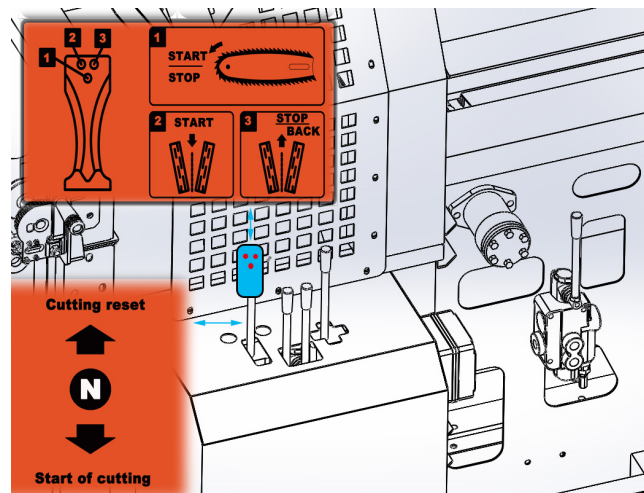

Fig. 47 – Saw Control Lever

- Once fully raised, lock the top roller lift arm.

Lock Top Roller out of the Way

The valve control lever is located on the right-hand side of the console.

1. Push the valve lever away from the operator to lock top roller clamp position.
2. Pull the lever back to unlock it and lower it back down onto the log.

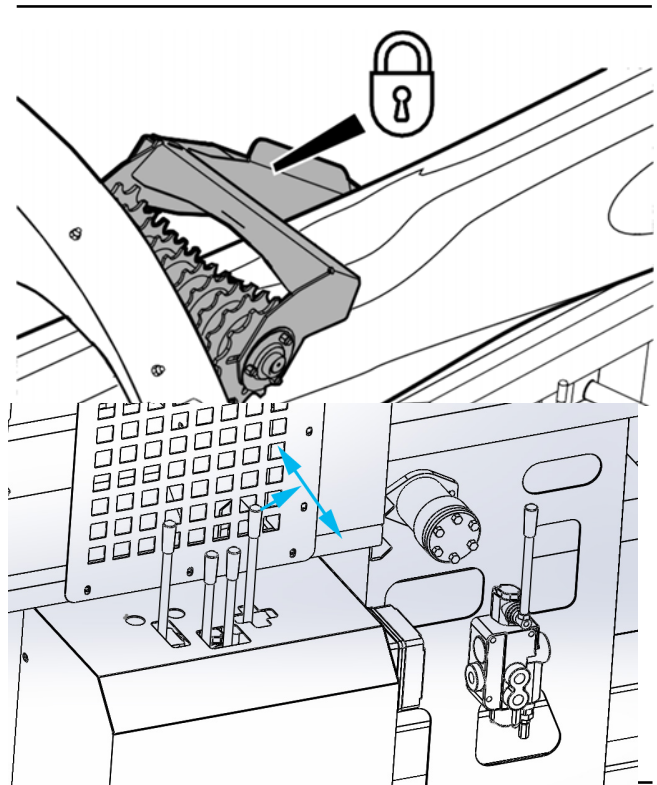

Fig. 48 – Top Roller Lift Arm Locked

6.4 Cutting

WARNING!



Risk of serious injury or death from flying debris or shot from broken saw chain. Stay behind protective shields when cutting. Keep ground personnel and bystanders outside perimeter of work area.

W044

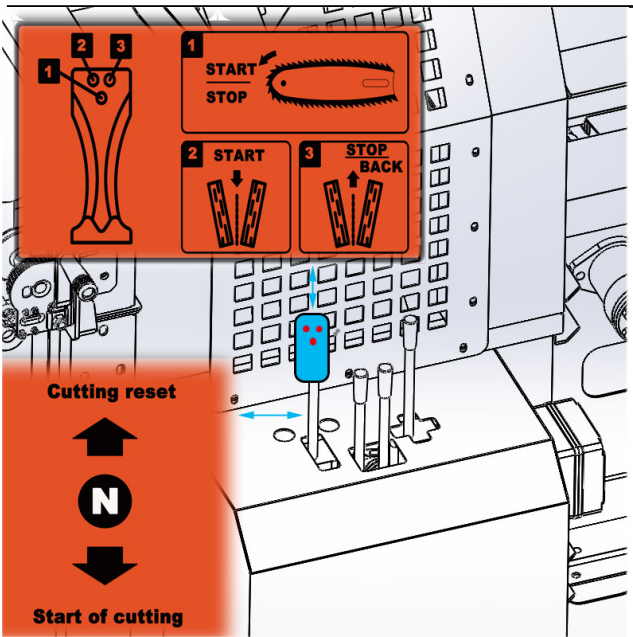

Fig. 49 – Saw Control Lever and Feed Rate Control

Procedure:

1. Pull the saw control lever back towards the operator to lower the saw and cut the log. The saw chain starts as the saw begins to move. The top roller locks down to hold the log in place. When the log is cut through, it falls into the splitting cradle.
2. Push the lever forward to raise the saw out of the way, ready for the next cut. The saw chain stops and the top roller returns to standby slight pressure as the saw is raised.

Adjust feed rate (raise/lower speed) on the fly with the rotary control valve knob. (The saw *chain* speed is not adjustable.)

IMPORTANT! When cutting, bar oil should be visible coming off the tip of the saw. If not, adjust the bar oil flow rate. See page 45.

Always make sure the saw chain is sharp and in good working order.

The top roller keeps a slight amount of down pressure on the log at all times. When the saw is lowered for the cut, down pressure increases in the lift cylinder to clamp down on the log.

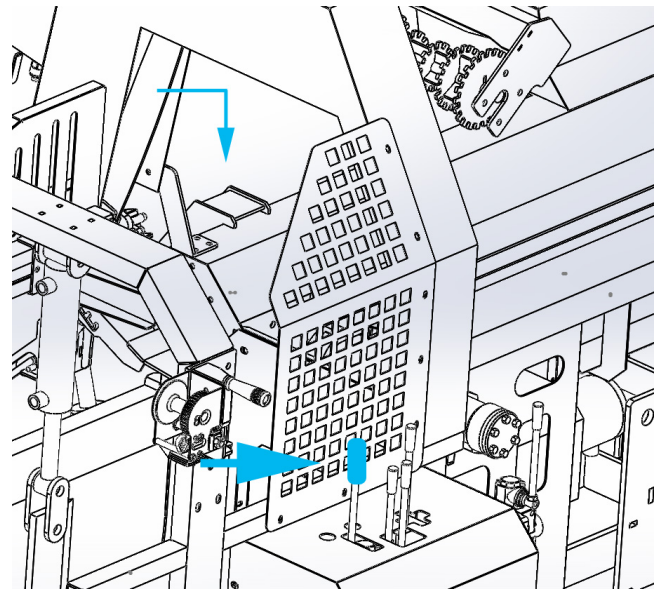

00402

Fig. 50 – Cutting the Log

6.4.1 Powered Top Roller (option)

The powered top roller works together in series with the infeed conveyor. It assists feeding logs into the saw, and starts and stops with the infeed conveyor.

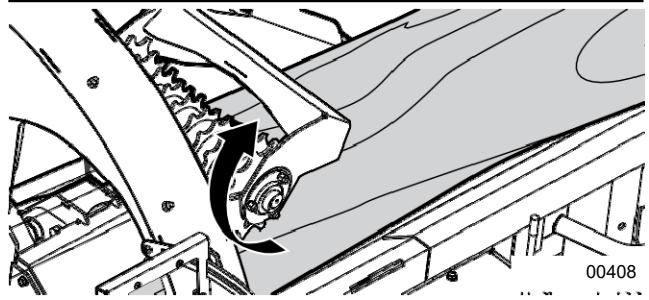

00408

Fig. 51 – Powered Top Roller

The powered top roller is a dealer-installed option.

6.4.2 Bar Oil Flow Rate Adjustment

Adjust bar oil flow rate by opening or closing the flow control valve on the side of the bar oil reservoir. Ambient temperatures affect oil flow rate. Adjust as required.

Bar oil should be visible coming off the end of the saw chain during operation.

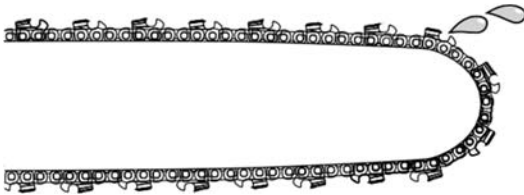

00388

Fig. 52—Bar Oil Visible coming off of Chain

- Turn the knob out counter-clockwise to increase oil flow to the saw.
- Turn it in clockwise to decrease the oil flow rate.

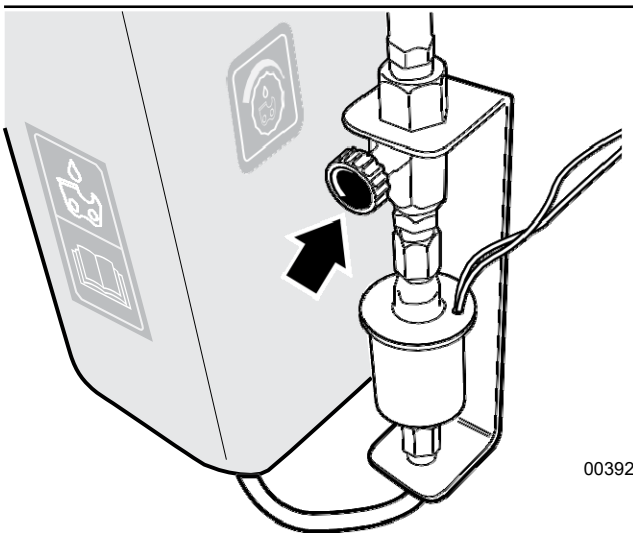
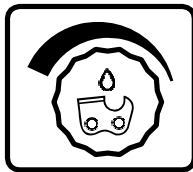

00392

Fig. 53—Bar Oil Flow Control

6.5 Splitting

Adjust Wedge Height

The control lever is on the upper part of the control panel, to the far left-hand end. Wedge height can be quickly adjusted while working.

NOTE: A 6-way splitting wedge is available as an accessory. To change the wedge, see procedure on page 61.

- Center wedge height on the log. Raise or lower depending on log size.

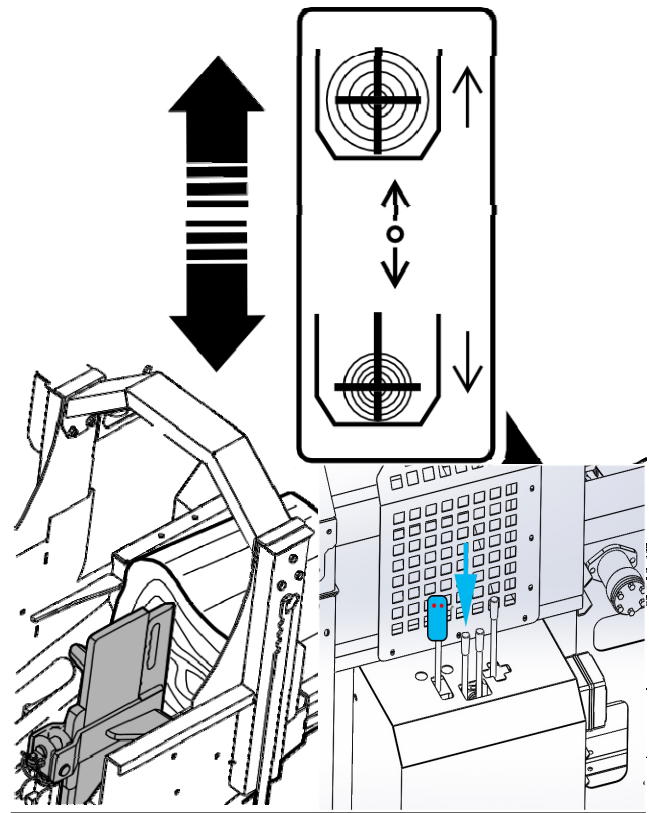

Fig. 54 – Adjust Wedge Height

! CAUTION!



Risk of pinching or crushing hazard! Never reach into the splitting cradle to reposition a log. Use a log peavy (cant hook) or other tool.

W043

Split the Log

1. Press the 2 button to start the splitting.
2. Press the 3 button retract the ram till the end.

Advance the Log

Push the infeed conveyor valve handle down to advance log up to stop guide, ready for the next cut.

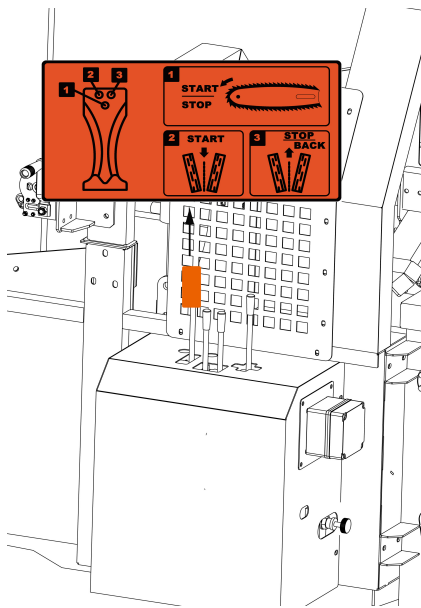

00404

Fig. 55 – Splitter Control

Start the Conveyor (as equipped)

- If equipped with the integrated conveyor, pull the conveyor control lever back towards the operator.

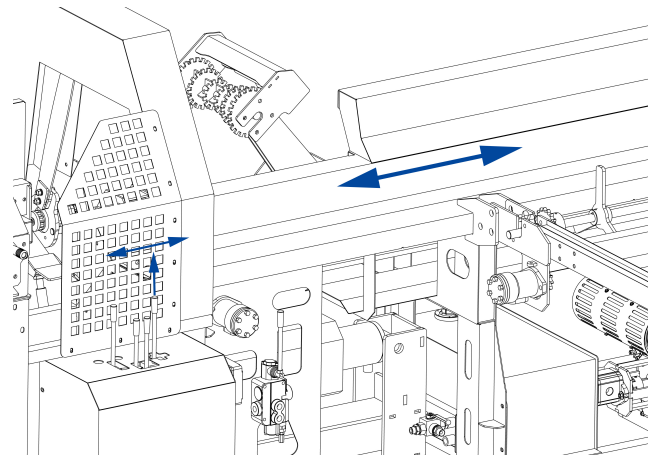
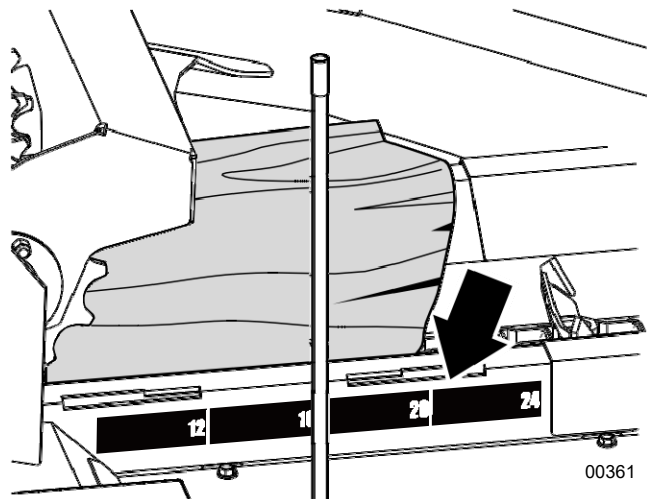

Fig. 56 – Conveyor Control Lever

3. Push the next block through the wedge to finish the split of the first. The split wood is shoved out onto the conveyor as each additional log moves through the machine.
4. Continue advancing and cutting up to the end of the log.

End of the Log

5. Use the length guide on the side of the infeed conveyor as a reference for final log cuts. The guide indicates the length of log remaining, measured from the saw.



00361

Fig. 57 – Length Guide on Operator Side of Infeed Conveyor

7. Transporting

- Clear out all logs and clean all debris off the wood processor.
- Raise live deck so it is in the vertical transport position.
- Check that all lights and reflectors required are not damaged and cleaned.
- Remove or secure any loose objects. Place tools in the toolbox.
- Raise/fold-up the conveyor

About the (3.2m) Integrated Conveyor

- Use the hand winch to raise it up to vertical.
- Install the chute lock arm and lynch pin.

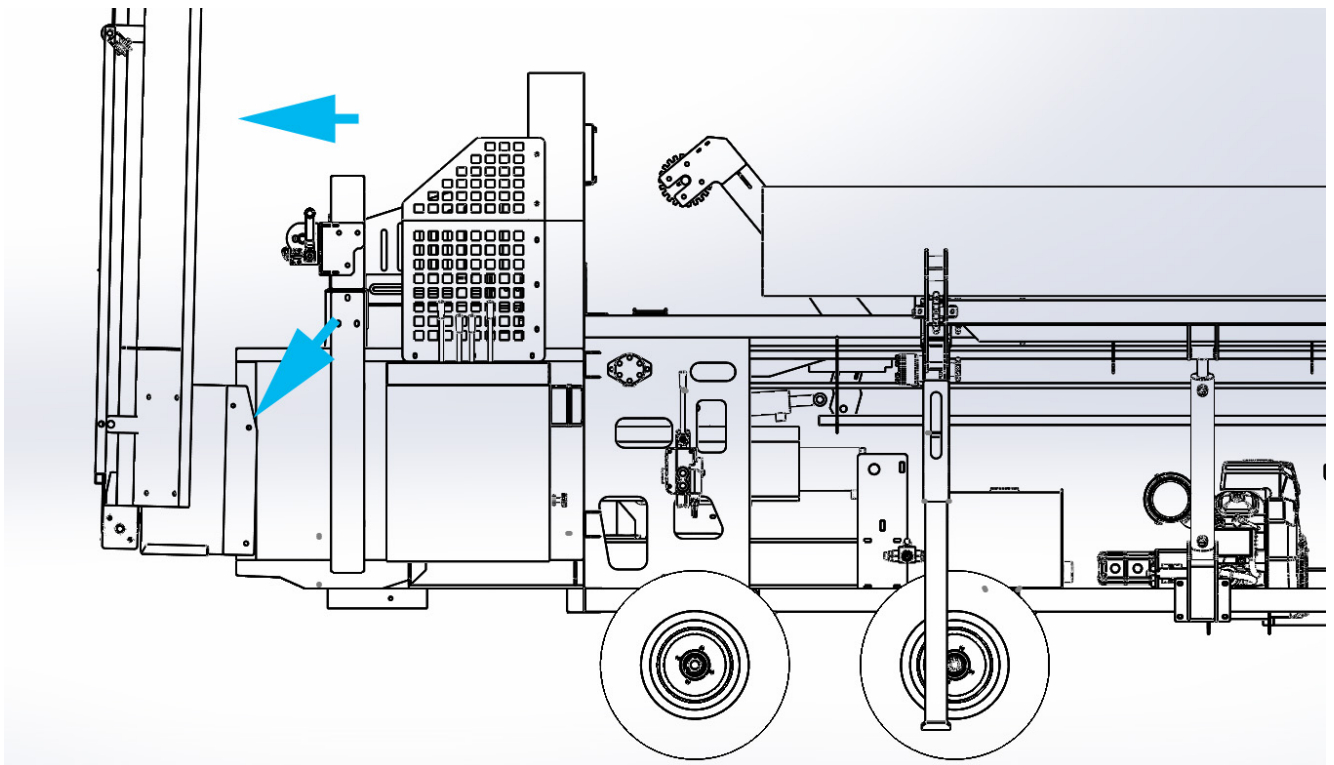

Fig. 61 – 10.5 ft (3.2 m) Conveyor in Transport Position

IMPORTANT! When unfolding the conveyor for use, make sure that the chain engages over the sprocket as it tightens by the action of unfolding and clamping.

Raising Live Deck

1. Remove the hitch pins and swing the support legs up. Reinsert the hitch pins.
2. Pull out the lock pins and push the live deck up fully vertical. (Approximately 50 lb [23 kg] force required.)
3. Reinstall the pins to lock it.

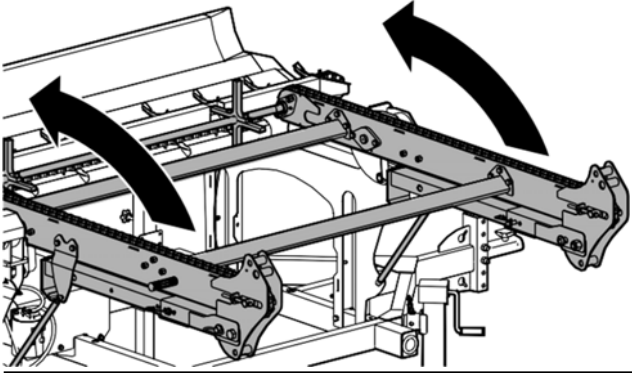
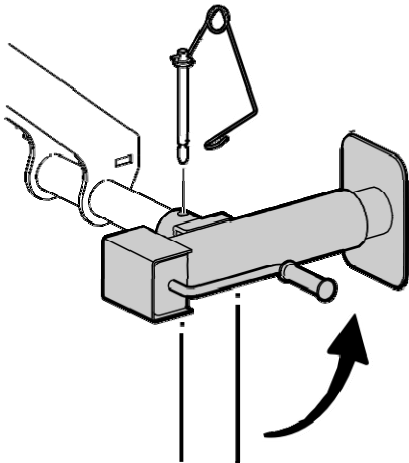

Fig. 63 – Raise Live Deck

NOTE: If the log lifter option is installed, reverse the procedure described on page 28 to raise the live deck up into the transport position.

4. Rotate crank jacks and re-pin in the horizontal travel position.



00431

Fig. 64 – Rotate Crank jacks

7.1 Attaching and Unhooking

Make sure the area in front of the machine is clear of debris and other equipment.

1. Using the front crank jack, raise the wood processor so that the coupler is higher than the ball hitch on the tow vehicle.

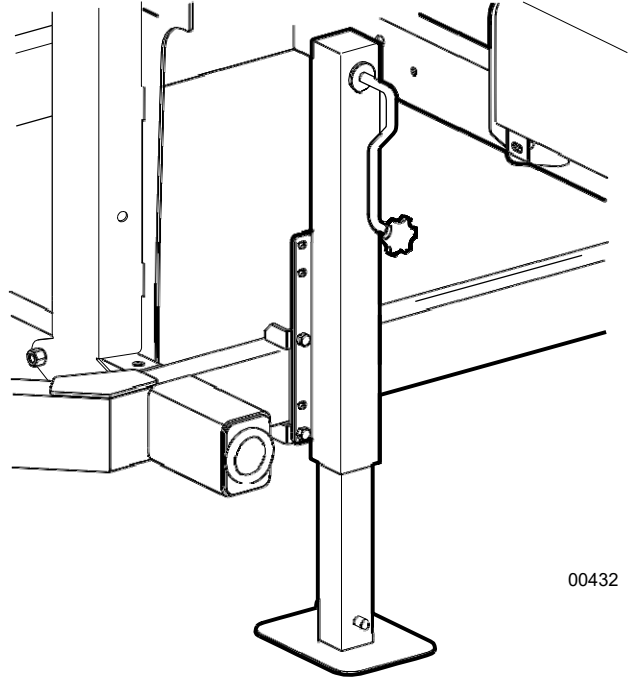

00432

Fig. 65 – Front Crank Jack

2. Slowly back the tow vehicle until the hitch coupler and the ball are aligned.
3. Open the coupler latch.
4. Lower the crank jack so the hitch coupler slides over the ball.
5. Flip the coupler latch to lock the coupler around the ball.
6. Install the snapper pin through the coupler latch.
7. Attach the safety chains securely. Cross the chains under the hitch.
8. Connect the light harness and check the function of all lights.

Raise the front jack up all the way.

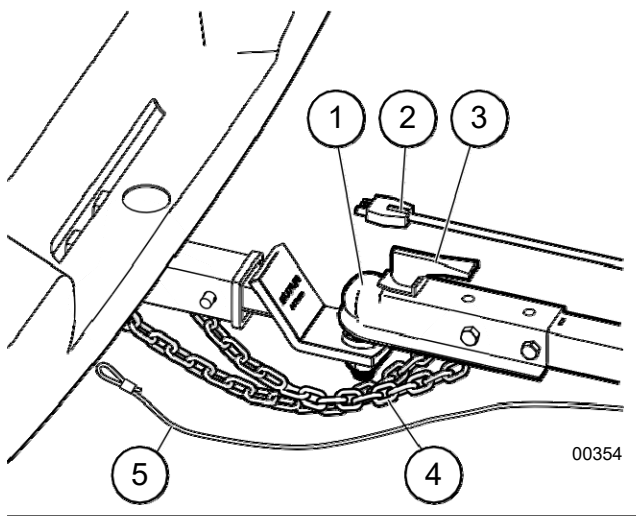

Fig. 66 – Attaching to a Tow Vehicle

1. Hitch Coupler
2. Trailer Light Harness
3. Coupler Latch
4. Safety Chains Crossed under Trailer Tongue
5. Trailer Breakaway System Cable

9. Reverse procedure when unhooking. Make sure there is enough space behind the machine to safely back up into position. Refer to *Machine Set-Up* on page 26.

7.2 Transporting on a Roadway

1. Make sure that the machine is securely attached to the tow unit with a retainer through the hitch latch.
2. Check that all components of the wood processor are secure for travel.
3. Check the function of all lights and electric brakes.
4. Do not allow riders. If the wood processor is equipped with an operator seat, fold it up out of the way.
5. Never exceed 50 mph (80 km/h). Slow down when cornering or encountering rough road conditions.

7.3 Trailer Breakaway System

The Trailer Breakaway System is designed to bring the wood processor trailer to a safe stop by activating the electric brakes should the trailer be accidentally disconnected from the tow vehicle while driving.

The switch is wired to the wood processor battery. It contains a pin attached to a wire cable connected to the tow vehicle. In the event the trailer becomes disconnected, the pin is pulled out of the switch

applying the brakes and stopping the trailer.

For the system to function properly, the electric brakes on the wood processor trailer must be operational, the processor 12-volt battery must be charged, and the switch cable must be attached to the tow vehicle.

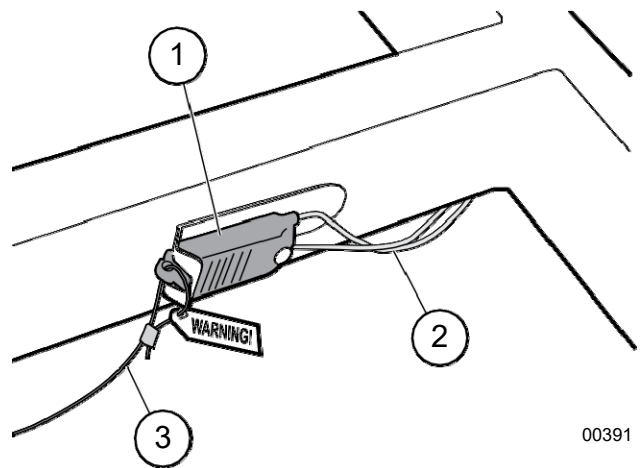

Fig. 67 – Trailer Breakaway Switch

1. Trailer breakaway switch on processor frame
2. Wires connecting switch to wood processor battery
3. Wire cable connecting switch pin to tow vehicle

! WARNING!

Never use the Trailer Breakaway Switch as a parking brake. The switch is there to safely stop the trailer in the event it becomes accidentally disconnected from the tow vehicle.

Using it as a parking brake when un-hooked drains the machine's battery and would then cause it to be ineffective in an emergency. Once the battery charge depletes, the brakes release and the trailer could move unexpectedly.

W042

7.3.1 Attaching Breakaway Cable

- Connect the breakaway wire cable to the tow vehicle so it is independent of safety chains and wire harness. There should be a clear path for the cable from the switch to the tow vehicle. The cable must be able to pull the pin directly out of the switch in an emergency.
- Make sure the pin is installed in the switch.
- Never loop the cable through the safety chains or over the trailer tongue.

7.3.2 Machine Dimensions

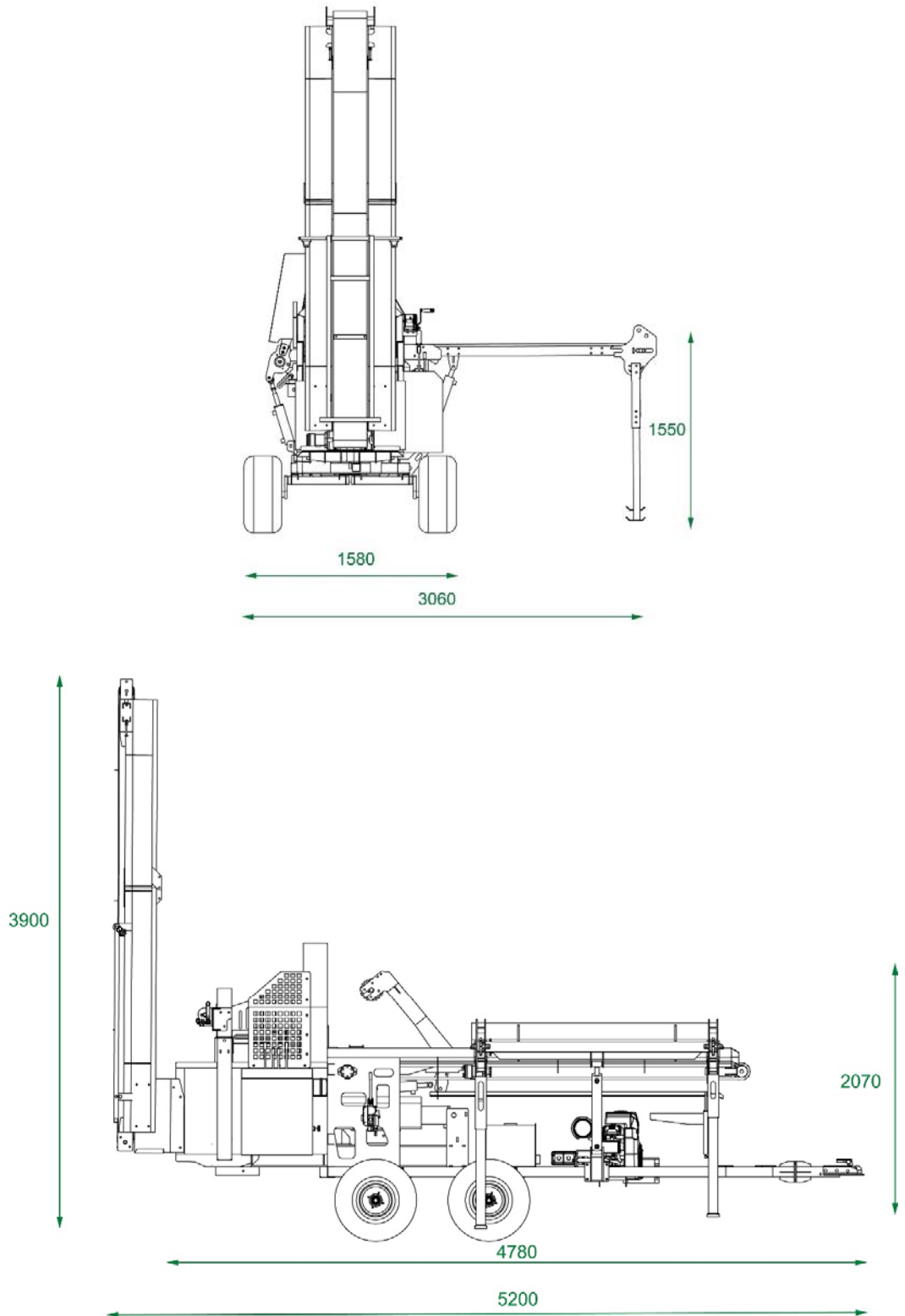

Fig. 68 – Overall Dimensions

8. Storage

8.1 Placing Wood Processor in Storage

After the season's use or when the machine will not be used for a period of time, completely inspect all major systems of the wood processor. Replace or repair any worn or damaged components to prevent any unnecessary down time at the beginning of the next season.

Procedure

1. Clear out all wood material from the machine.
2. If storing for more than 1 month, add stabilizer to the fuel system. Run the engine for a few minutes to allow the stabilized fuel to cycle through. Refer to the engine manual for further information on engine storage.
3. Thoroughly wash the machine to remove all dirt, mud, and debris.
4. Inspect all moving parts and remove any entangled material.
5. Fold up the live deck.
6. Block or chock the wheels.
7. Cover the machine with a waterproof tarp, if storing it inside is not possible.

8.2 Removing from Storage

When removing this machine from storage, follow the pre-operation checklist. See *page 35*.

9. Service and Maintenance

WARNING!

Risk of serious personal injury. Stop engine before performing ANY service or maintenance procedure. Reinstall all covers and guards removed before putting machine back into service.

W033

WARNING!

Shut down the machine and allow it to cool before performing any service, maintenance or inspection procedure. Engine components and oil may be hot enough to cause injury.

Make sure the machine is in a Safe Condition to work on. Review Maintenance Safety beforehand.

W041

9.1 Fluids and Lubricants

1. Engine Oil

SAE 10W-30 motor oil of API service class SJ is recommended for general use. **Refer to the engine manufacturer's manual for maintenance and service information.**

2. Grease

Use an SAE multi-purpose high temperature grease with extreme pressure (EP) performance. Also acceptable is an SAE multipurpose lithium-based grease.

3. Engine Fuel

This engine is certified to operate on unleaded gasoline with a pump octane rating of 87 (R+M)/2 or higher, research Octane Number (RON) 90 octane minimum. Gasoline up to 10% ethyl alcohol, 90% unleaded is acceptable.

4. Hydraulic Oil

Use Dexron® III ATF for all operating conditions. **AW-46** or **AW-32** are acceptable substitutes.

5. Storing Lubricants

Your machine can operate at top efficiency only if clean lubricants are used. Use clean containers to handle all lubricants. Store them in an area protected from dust, moisture and other contaminants.

9.2 Maintenance Schedule

Perform maintenance procedures at time shown or hour interval, whichever comes first.

As Required	
Check the condition of all hydraulic lines, hoses and fittings. Replace any that are damaged.	
Check that all fasteners are tight. Check wheel lug torque. See <i>page 68</i> .	

Every 8 hours or Daily	
Check engine oil level.	See <i>page 51</i>
Check hydraulic oil level.	See <i>page 51</i>
Perform Pre-operation check	See <i>page 35</i>

Every 50 hours or Annually	
Clean engine air filter	See <i>page 56</i>
Inspect hydraulic oil quality	See <i>page 51</i>
Inspect battery	See <i>page 57</i>
Grease entire machine	See <i>page 53</i>
Check drive chain tension	See <i>page 62</i>

Every 100 hours or Annually	
Change engine oil	See engine manual
Check tire pressure	See rating on tire sidewall
Change hydraulic oil filter	See <i>page 55</i>
Change engine air filter	See <i>page 56</i>
Clean machine. Remove debris and entangled material.	—
Change fuel filter	See engine manual

9.3 Greasing

- Use a hand-held grease gun for all greasing.
- Wipe grease fitting with a clean cloth before greasing to avoid injecting dirt and grit.
- Replace and repair broken fittings immediately.
- If fittings will not take grease, remove and clean thoroughly. Also clean lubricant passageway. Replace fittings if necessary.

Location	Grease Points – Every 50 hours or annually
1	Live deck drive and tilt – 4 points
2	Infeed conveyor drive – 2 points
3	Log dropper – 1 point
4	Saw drive pivot – 2 points
5	Saw rotate cylinder – 1 point
6	Top roller arm pivot – 4 points
7	Conveyor drive – 2 points

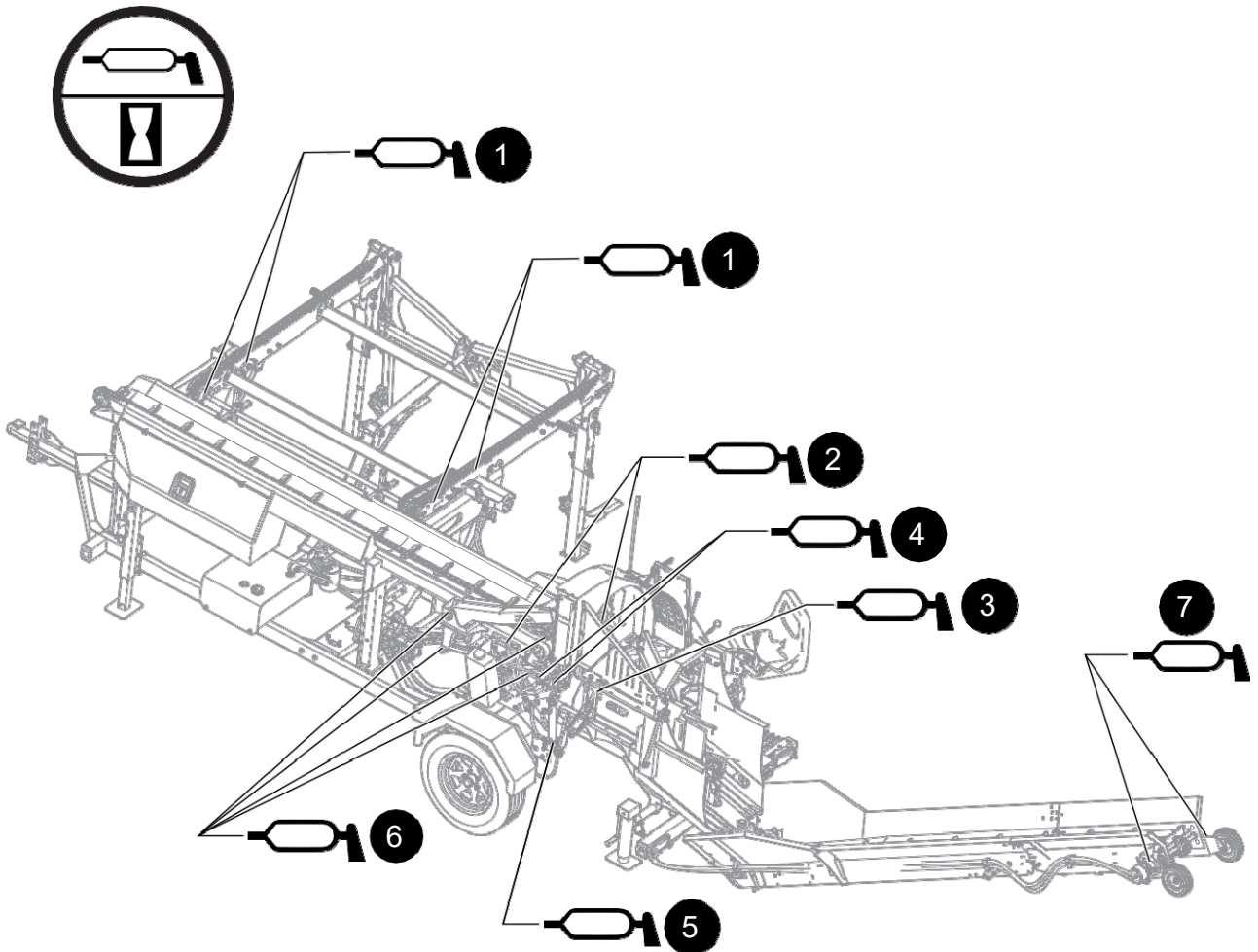

Fig. 69 – Grease Points

9.4 Hydraulic Oil – Changing

CAUTION!



Risk of burns to exposed skin. Hydraulic oil becomes hot during operation. Hoses, lines and other parts become hot as well. Wait for the oil and components to cool before starting any maintenance or inspection work.

W028

Change the hydraulic oil in the reservoir at **100 hours** of operation or annually.

IMPORTANT! Clean the suction strainers and return filter in the tank at the same time.

- Hydraulic oil type: **Dexron III ATF** or **AW-64 & AW-32**.
- Hydraulic oil tank capacity: **26 US gal (102 L)**
The hydraulic tank drain plug is located under the machine. A 3/8" Allen wrench is required to remove it.

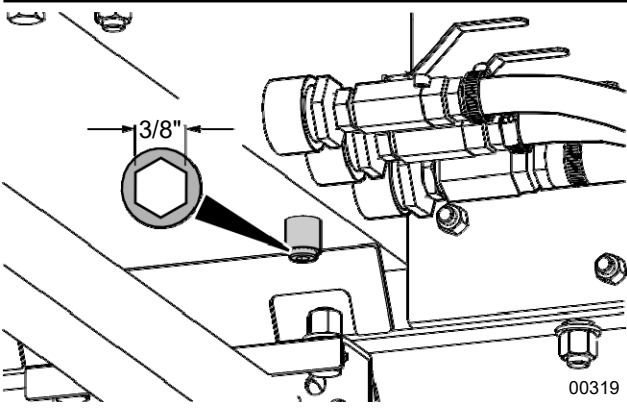

Fig. 70 – Hydraulic Tank Drain Plug

Procedure

1. Have a drain pan ready of suitable capacity.
2. Clean the area around drain and remove the drain plug.
3. Allow the oil to fully drain, then flush the tank. Dispose of used oil in a environmentally acceptable fashion.
4. Install the drain plug.
5. Clean the suction strainer filters before filling the tank.

9.4.1 Clean Suction Strainers

The three suction strainers are made of stainless steel screen and are reused. The strainers are located on the bottom of the tank at the pump suction line connections.

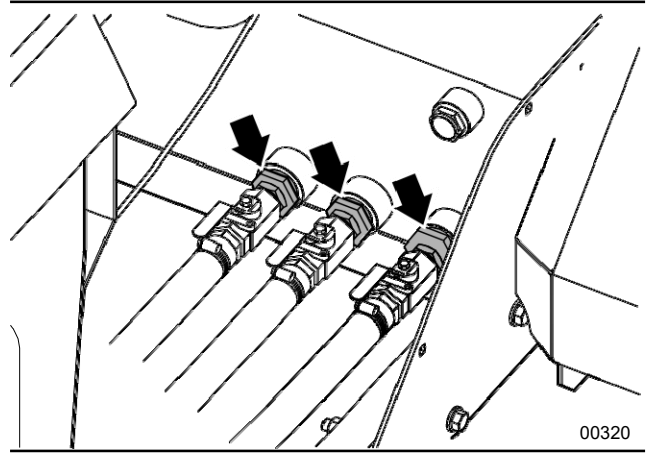

Fig. 71 – Suction Strainers

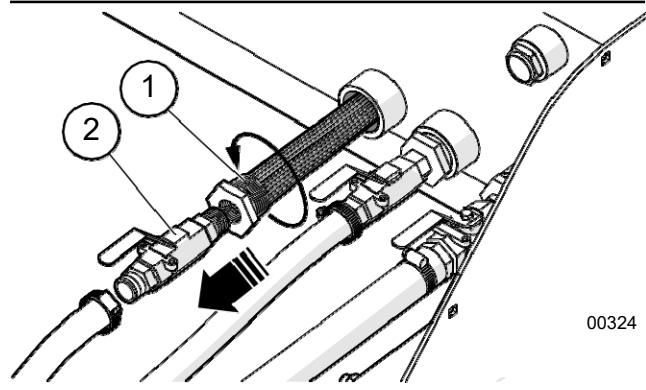

Fig. 72 – Suction Strainer Removal

1. Suction Strainer
2. Shut-off Valve

1. Remove the hose and shut-off valve.
2. Remove the suction strainer and place it in a solvent tank. Use a small brush to clean it. Examine the strainer screen and replace it if there are holes or damage.
3. Dry the suction screen thoroughly, then re-install the strainer, valve and suction hose.

9.4.2 Hydraulic Oil Filter – Cleaning

The hydraulic filter is made of stainless steel screen and is reused. The filter is located on top of the hydraulic oil tank.

Procedure

1. Remove the cover over the hydraulic tank.

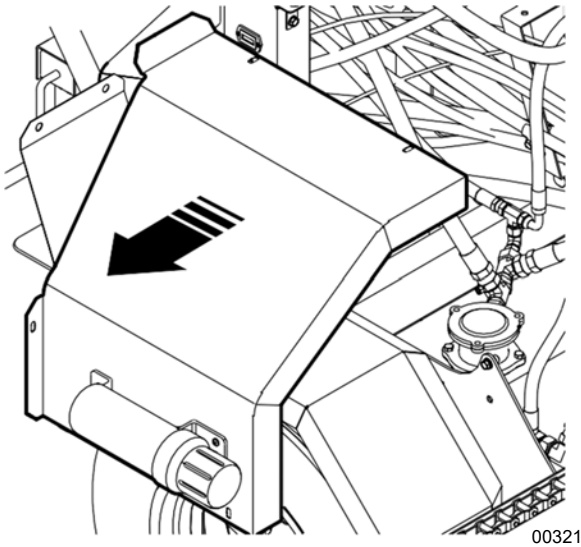

Fig. 73 – Hydraulic Oil Reservoir Cover

2. Have a drain pan ready to catch any dripping oil.

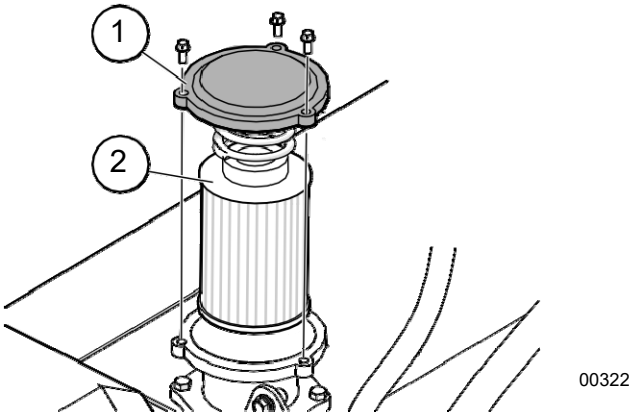

Fig. 74 – Hydraulic Oil Filter Element

1. Oil Filter Cover
2. Hydraulic Oil Return Filter Element

3. Remove the three screws on the filter cover and pull the cover off.
4. Remove the filter element and clean the bottom of the bowl.
5. Check that the O-rings are not damaged. If they are, replace them.

6. Place the filter element in a solvent tank and use a small brush to clean it. Examine the screen and replace it if there are holes or damage.
7. Reinstall the filter cover and tighten the screws to **44 lbf•in (5 N•m)**.
8. Fill the tank with clean oil. The oil is at the proper level is when it fills the top half of the glass window.

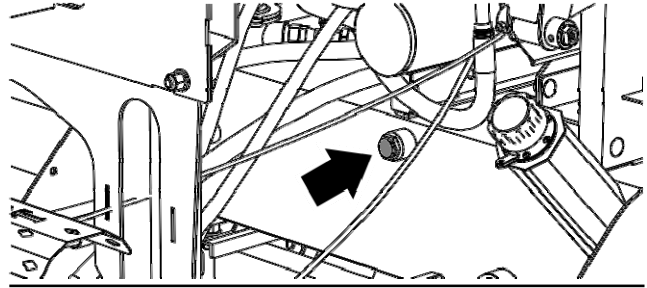
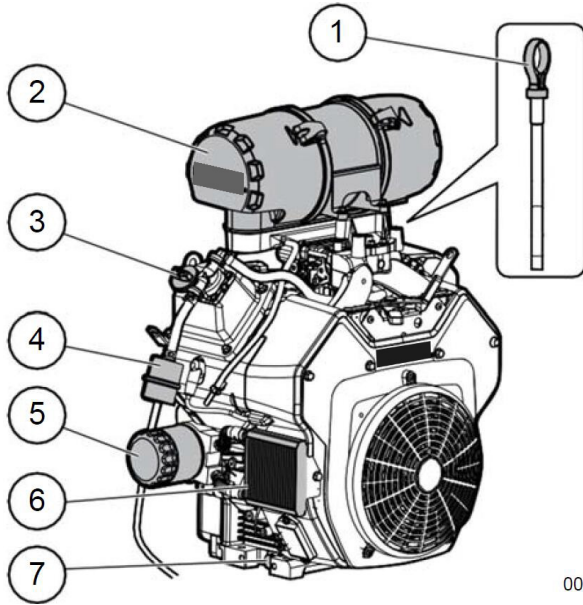

Fig. 75 – Oil Level Sight Glass

9. Reinstall the tank filler cap.

9.5 Engine

For further information on the engine and components, refer to the engine manual provided in the manual tube.



00326

Fig. 76—Engine Components

1. Oil Level Dipstick
2. Air Cleaner
3. Oil Filler Cap
4. Fuel Filter
5. Oil Filter
6. Oil Cooler
7. Oil Drain Plug

9.6 Engine Air Cleaner

Check air cleaner element every 50 hours of operation. Check it more frequently during dusty, dirty conditions.

Replace air filter element and check inner element at 250 hours of operation or annually.

Replace inner element at 500 hours.

A dirty air filter can restrict air flow to the carburetor, reducing engine performance. If the engine is operated in very dusty areas, clean the air filter more often than specified.

IMPORTANT! Operating the engine without an air filter, or with a damaged air filter, can allow dirt to enter the engine, causing rapid engine wear. This type of damage is not covered by warranty.

Inspection

Remove the air cleaner cover and inspect the filter elements. Clean or replace dirty filter elements. Always replace damaged filter elements.

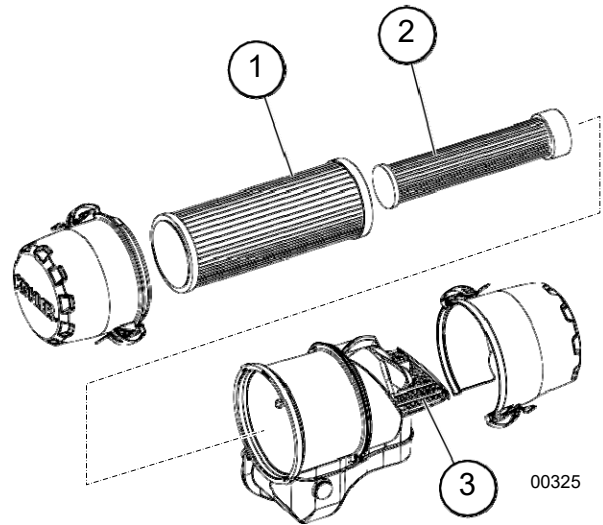

00325

Fig. 77 – Engine Air Cleaner

1. Element
2. Inner Element
3. Inlet Screen

NOTE: Refer to the engine manual for further information on servicing the air cleaner.

9.7 Servicing the Battery

Review *Battery Safety* on page 13.

CAUTION!

Risk of explosion or fire! Do not let metal objects come in contact with the battery terminals. Arcing can cause a fire or explosion. Cover terminals if working near batteries.

W021

CAUTION!

Risk of burns! Battery electrolyte is extremely corrosive and poisonous. Contact with the eyes, skin or clothing can result in severe burns or other serious personal injury. If contact occurs seek medical attention immediately. Handle batteries carefully.

W029

CAUTION!

Battery posts, terminals and related accessories contain lead and lead compounds. These chemicals are known to cause cancer and birth defects or other reproductive harm. Wash hands after handling.

W031

9.7.1 Removing the Battery

1. Disconnect negative (–) cable first, then positive (+) cable.
2. Remove battery hold-down bracket and battery from machine.

9.7.2 Installing the Battery

1. Install battery hold-down bracket.
2. Coat terminals with dielectric grease or petroleum jelly.
3. Connect positive (+) cable first, then negative (–) cable.

9.7.3 Cleaning the Battery

1. Disconnect negative (–) cable first, then positive (+) cable.
2. Clean battery cable ends and terminals with wire brush. Rinse with a weak baking soda solution.
3. Coat terminals with dielectric grease or petroleum jelly.
4. Connect positive (+) cable first, then negative (–) cable.

9.7.4 Charging the Battery

Be familiar with procedures for charging and testing a battery. Read and follow the manufacturer's instructions for the battery charger.

WARNING!

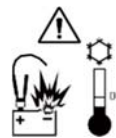

Charging a frozen battery can cause it to explode. Warm the battery to 60 °F (16 °C) before charging.

W030

Remove the battery from the machine to recharge it.

1. Use a battery carrier to lift the battery or place hands at opposite corners to avoid spilling electrolyte.
2. Place battery in a well-ventilated area.
3. Connect positive (+) lead of charger to positive (+) terminal, and negative (–) lead to negative (–) terminal.
4. Charge battery according to the instructions from battery charger manufacturer and battery manufacturer.

9.7.5 Jump Starting

Booster battery must be 12-volt, or installed in a system that is 12-volt, negatively grounded.

1. Connect positive (+) jumper cable to positive terminal of discharged battery.
2. Connect the other end of the same jumper cable to positive (+) terminal of booster battery.
3. Connect one end of the second jumper cable to negative (–) terminal of booster battery.
4. Make the final jumper cable connection to engine block or the furthest ground point, away from the discharged battery and fuel tank.
5. Start engine.

6. After engine starts leave cables connected for one to two minutes.
7. Disconnect jumper cables in reverse order of installation.
8. Operate unit as normal to charge battery.

9.8 Electrical System – General

IMPORTANT! When assembling or replacing wire harnesses, apply a thin coating of silicone dielectric grease to the harness connectors.

Clean off any corrosion or loose particles, then apply a small amount to the surfaces of the connectors where they meet. The grease helps to stop any possibility of future corrosion.

Reassemble the connection. Wipe off any grease that squeezes out.

9.9 Axles and Suspension

Except for periodic inspection of the fasteners used to attach the axle to the frame, no other suspension maintenance is required.

For further information on maintenance and inspection procedures regarding brakes, hubs, bearings and seals, refer to the manufacturer.

The axle suspension system is a torsion arm type suspension completely self-contained within an axle tube.

The axle provides suspension through a steel torsion bar surrounded by four rubber cords, encased in the main structural member of the axle beam.

The wheel/hub spindle is attached to the torsion arm, fastened to the rubber encased bar. As load is applied, the bar rotates causing a rolling / compressive resistance in the rubber cords.

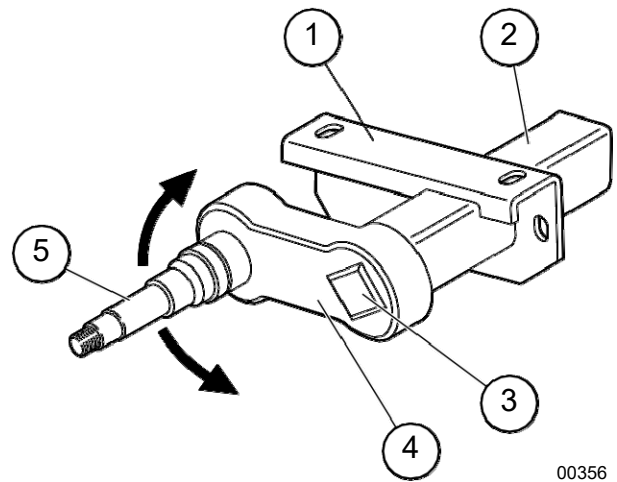
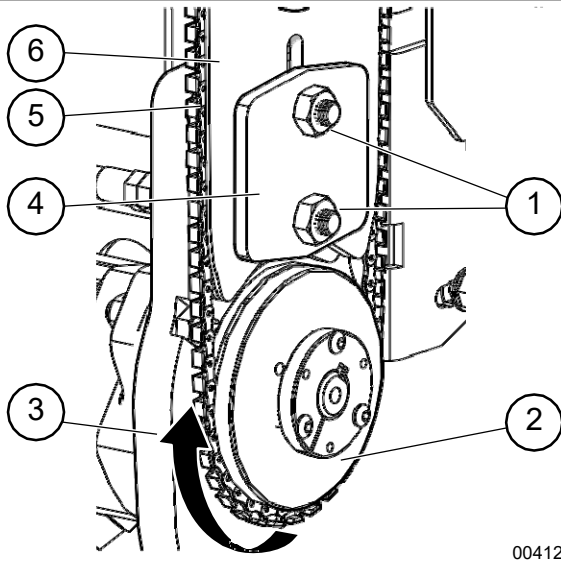

Fig. 78 – Axle

1. Spindle
2. Mounting Bracket
3. Axle Tube
4. Torsion Bar
5. Torsion Arm

IMPORTANT! Do not weld on the axle beam. Heat generated from welding could damage the rubber suspension cords.

9.10 Saw Chain Maintenance



00412

Fig. 79 – Saw Parts

1. Bar Nuts
2. Drive Sprocket
3. Direction of Chain Travel
4. Clamp plate
5. Cutting Chain
6. Guide Bar

9.10.1 Sharpening

Use chain and bar in sets to equalize wear. Keep chain sharp to make faster cuts and reduce energy required to make the cuts.

IMPORTANT! Refer to the manufacturer for instructions on sharpening the saw chain.

- Before sharpening, clean the saw chain to remove dirt, debris and bar oil so it can be inspected thoroughly.
- Inspect for broken, cracked, damaged or missing chain parts.
- Look for signs of excessive chain stretch. Stretch indicates wear occurring to the flange of the rivet and holes in the drive links.
- Inspect the chain chassis for abnormal wear patterns, which are indicators of issues with the guide bar and drive socket.
- Discard the chain if it has broken, parts are missing, there is excessive stretch, or it has loose rivets.

9.10.2 Bar Chain, Remove / Replace

NOTE: A tool is provided in the toolbox for the bar nuts and bar chain tensioner.

1. Open the saw access door.

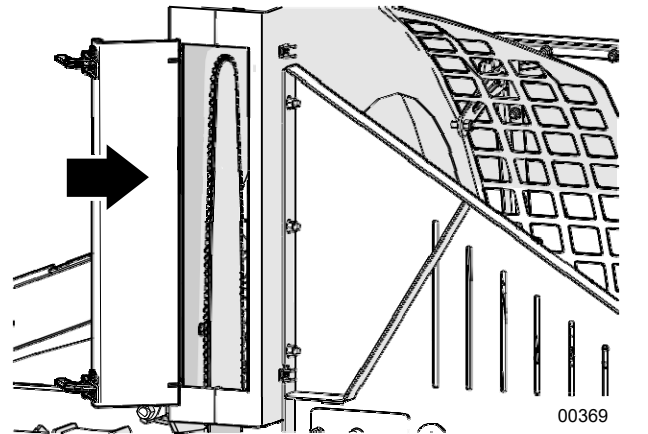

00369

Fig. 80 – Saw Access Door

2. Loosen off bar nuts.

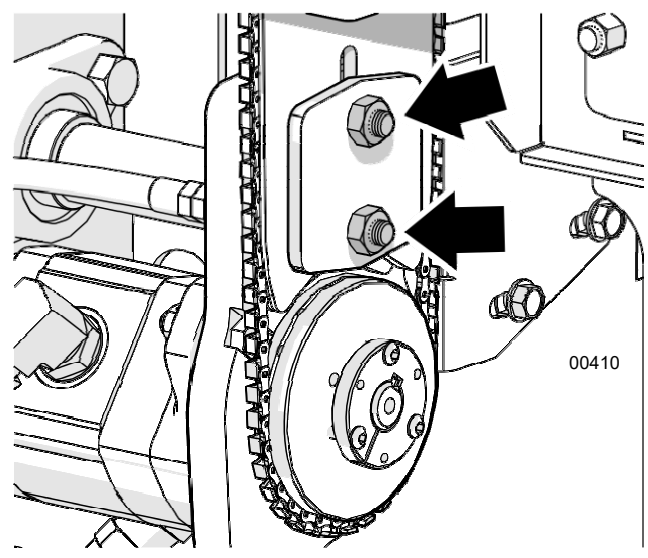

00410

Fig. 81 – Bar Nuts

3. Turn adjusting screw counter-clockwise to loosen chain so it can then be removed.

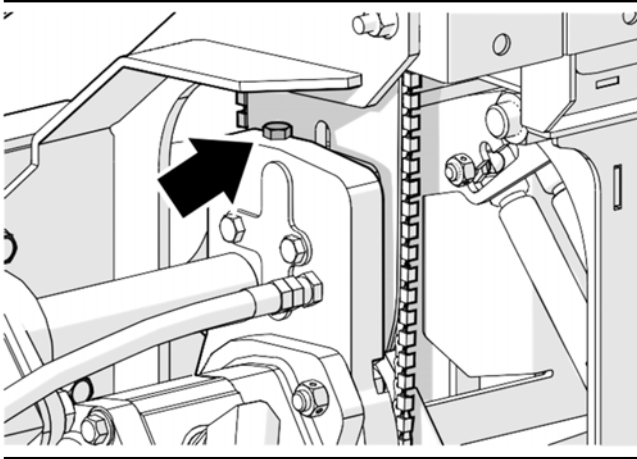

Fig. 82 – Adjusting Screw

To reinstall the bar chain, reverse the procedure. Tension bar chain as described.

9.10.3 Bar Chain, Tensioning

1. Turn the adjusting screw clockwise to tighten the chain. Turn it counter-clockwise to loosen.

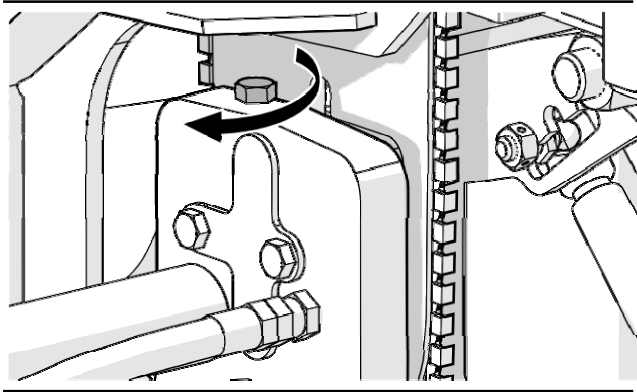

Fig. 83 – Turn Adjusting Screw Clockwise to Increase Chain Tension

2. Grasp the chain at the mid point of the guide bar and pull the saw chain away from the bar rails. The saw chain chassis should come out of the bar groove and away from the bar rails 1/8 inch (3 mm). It should snap back against the bar rails when released.

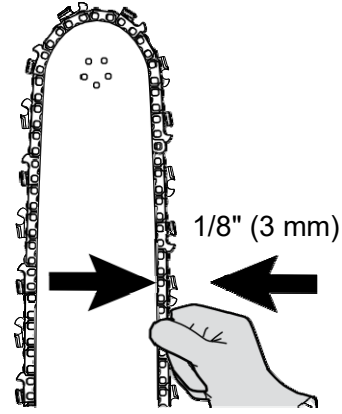

Fig. 84 – Saw Chain Tension

9.11 Saw Lubrication

Your cutting system (saw chain and guide bar) must receive sufficient lubrication to prevent excessive chassis wear. The saw is equipped with an automatic bar oiler that starts when the saw is activated.

As a guide, the minimum amount of lubrication recommended for a .404"-pitch cutting system is 1 oz (33 cc) for every minute of saw use.

IMPORTANT! Never use hydraulic fluid in place of bar oil. Hydraulic fluid is not an adequate cutting system lubricant.

At startup, adequate time must be allowed for lubrication to reach the cutting system. In cold weather, or with the addition of a new guide bar or saw chain, the system will require additional time. Run the saw chain until lubrication can be observed leaving the tip of the guide bar.

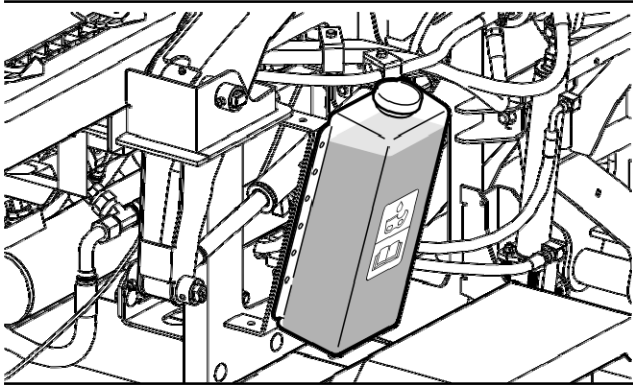

Fig. 85 – Bar Oil Reservoir

9.12 Splitting Wedge, Changing

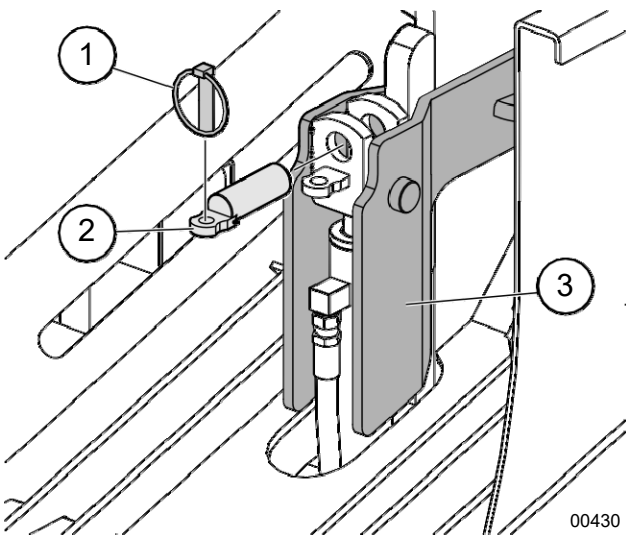

Fig. 86 – Splitting Wedge

1. Lynch Pin
2. Wedge Pin
3. Splitting Wedge

Either a 4-way or 6-way wedge can be used on the splitter. To change it, follow these steps:

1. Remove lynch pin (1).
2. Lift and support the wedge (3), then remove the wedge pin (2).
3. Lift the wedge up over the support to remove it.
4. Install the wedge in the reverse manner.

9.13 Infeed Conveyor Chain, Tensioning

Drive chains can stretch during the first 50 hours of operation. This is normal wear in.

The infeed conveyor chain can stretch a slight amount and can require occasional adjustment. If excessive slack is observed, snug up the tension adjusters. Care must be taken the chain is not over adjusted, as this adds pretension into the chain and reduces chain life.

IMPORTANT! The main requirement of chain adjustment is to remove slack from the chain (take up the clearances in each link). It is easy to over tighten the chain, so great care is needed!

Measure conveyor chain slack from the topside. Pull the chain up at the middle and measure dimension at X. Measurement should be 3" (7.6 cm). Adjust accordingly.

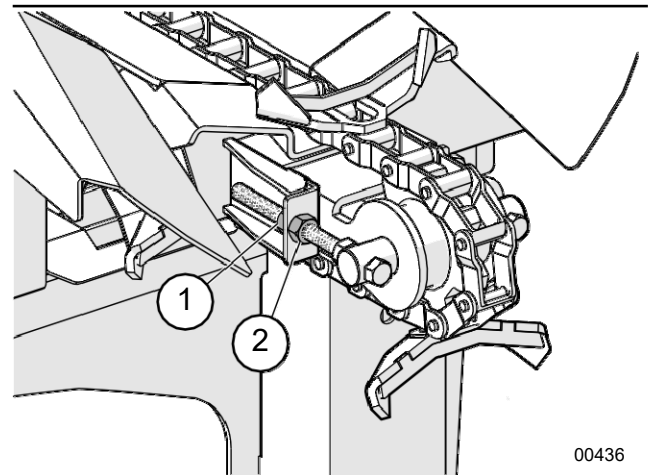
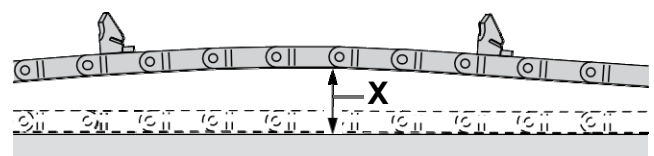

Fig. 87 – Infeed Conveyor Chain

1. Jam Nuts
2. Tension Adjuster Nut

1. Loosen jam nuts (1) on both sides.
2. Turn the tension adjuster nuts (2) on both sides to tighten the chain.
3. Tighten the jam nuts.

IMPORTANT! Adjust both sides equally.

9.14 Live Deck Chain, Tensioning

Drive chains can stretch during the first 50 hours of operation. This is normal wear in.

The live deck chain can stretch a slight amount and can require occasional adjustment. If excessive slack is observed, snug up the tension adjusters. Care must be taken the chain is not over adjusted, as this adds pretension into the chain and reduces chain life.

IMPORTANT! The main requirement of chain adjustment is to remove slack from the chain (take up the clearances in each link). It is easy to over tighten the chain, so great care is needed!

Measure conveyor chain slack from the topside. Pull the chain up at the middle and measure dimension at X. Measurement should be 1-1/2" (4 cm). Adjust accordingly.

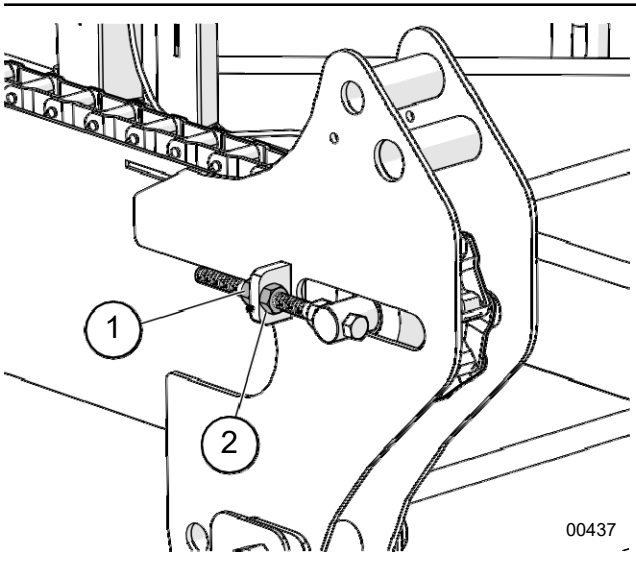
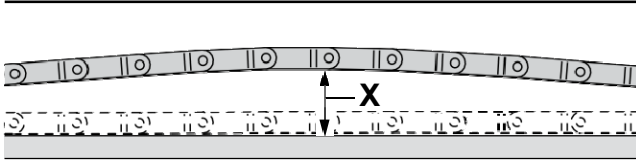

Fig. 88 – Live Deck Chains

- 1. Jam Nut
- 2. Tension Adjuster Nut

IMPORTANT! Adjust both sides equally.

- 1. Loosen jam nuts (1) on both sides.

- 2. Turn the tension adjuster nuts (2) on both sides to tighten the chain.
- 3. Tighten the jam nuts once proper tension is achieved.

9.15 Live Deck Drive Chain, Tensioning

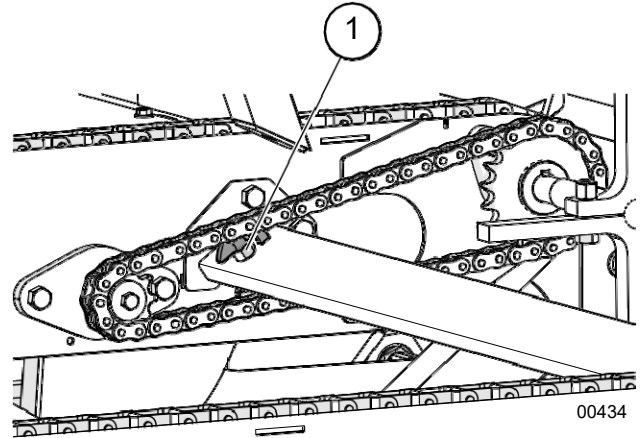

Fig. 89 – Live Deck Drive Chain

- 1. Turn chain tension adjuster nut (1) clockwise to tighten the chain. Chain should have 3/4"-1" (20-30 mm) sag.

9.15.1 Live Deck Drive Chain Lubrication

The infeed conveyor drive chain requires periodic lubrication. Use a brush to apply SAE 20 oil to the slack side of the chain on the roller links.

Reapply oil every 50 hours of operation or as necessary to prevent the chain from becoming dry.

10. Troubleshooting

The Trailer wood processor is a simple and reliable system that requires minimal maintenance.

If a problem remains unsolved after reading through this section, contact the local dealer, distributor or Equipment Inc. Before calling, have the serial number for the wood processor handy.

The following table lists problems that may be encountered, possible causes and solutions.

Problem	Cause	Solution
Splitter cylinder rod moves slowly or does not move.	Wood jammed around wedge.	Shut machine off and safely remove wood.
	Low hydraulic oil pressure.	Oil filter plugged. Change filter.
	Low hydraulic oil pressure.	Low hydraulic oil level. Add oil.
	Not enough pressure.	Call technician. System relief setting may be low.
	Low engine speed.	Check that choke is off. Check throttle is set to maximum.
Control handle doesn't go to neutral after splitter rod is fully retracted.	Detent set too tight.	Call technician. Adjustment required to detent on valve.
	Hydraulic fluid too cold.	Allow machine to warm up.
	Hydraulic fluid is contaminated.	Change hydraulic oil and filter.
Control handle goes to neutral before splitter rod is fully retracted.	Detent set too loose.	Call technician. Adjustment required to detent on valve.
Control handle doesn't go to neutral when released.	Valve may be damaged.	Valve may need to be serviced or replaced. Call technician.
Cylinder stops on contact with wood.	Hi-low valve not functioning.	Hi-low valve may need to be serviced or replaced. Call technician.
Wedge jumps.	Wood jammed sideways or at an angle.	Clear jammed wood.
Leaking hydraulic hose.	Hose worn or damaged.	Replace hose.
Leaking cylinder.	Seals worn.	Call technician. Seal replacement may be required.
Infeed conveyor or live deck does not operate.	Low hydraulic oil pressure.	Oil filter plugged. Change filter.
		Low hydraulic oil level. Add oil.
		Pump may need to be serviced or replaced. Call technician.
	Wood debris caught between the scrapers and conveyor trough.	Clear out debris.
	Scrapers frozen in the conveyor trough.	Free the infeed chain from the trough.
	Chain skipping, too loose	Tighten chain.
	Log is crooked or untrimmed branches are catching on the infeed conveyor.	Rotate log with peavy or trim branches off.
	Hydraulic conveyor is jammed resulting in no oil flow available.	

Problem	Cause	Solution	
Saw overheating; harder to cut.	Saw chain is dull.	Sharpen or replace chain.	
	Bar oil is low	Add oil.	
	Chain tension too loose.	Adjust chain tension.	
	Bar oiler not working.	Move oil reservoir to gravity feed mounting position on chain saw guard.	No power to pump as a result of pump failure, or pressure switch failure, harness issue. Call technician.
			Saw is cutting at an angle due wear on bar.
Log falls lengthwise into splitting chamber too often.	Dull chain is finishing the cut too slowly.	Sharpen or replace chain.	
	Log dropper set too light.	Set one or both gas struts to active on the log dropper.	
	Log dropper not centered under block.	Move log dropper to halfway point between saw and log length indicator.	
Wedge adjust cylinder does not lower.	Wood left under wedge prevents it from moving down.	Clear wood away from under wedge.	
Engine related issues.	Refer to your engine instruction manual for specific trouble shooting instructions / requirements.		

11. Specifications

Item	500H Trailer Wood Processor
Engine	22 hp electric start
Hydraulic Pump	(60 Lpm) / Stage 1 (15Lpm) / Stage 2
Cylinder Diameter / Stroke	4" / 26" (10 cm / 66 cm)
Splitter Control Valve	Single spool with auto return
Splitting Force	30 ton
Maximum Split Length	24" (60 cm)
Splitter Opening	26" (66 cm)
Maximum Log Diameter	19.6" (50 cm), 16" (41 cm) recommended
Maximum Log Length	16' (4.9 m)
Log Trough Length	12'-6" (3.8 m)
Wedge Configuration	4-way split (2-way possible); 6-way accessory available
Tire Size / Type	ST205/75R15 LRD / Radial Trail Highway tire
Ball Hitch Size	2" ball coupler and safety chains
Tongue Weight	480 lb (218 kg) estimated
Suspension	4000 lb (1814 kg) Suspension axle
Trailer Light Package	Optional
Weight	3,700 lb (1 450 kg) estimated
Dimensions — Live Deck Lowered (L x W x H)	19'-4" x 9'-6" x 6'-4" (5.89 m x 2.89 m x 1.93 m)
Dimensions — Live Deck Raised (L x W x H)	19'-4" x 5'-6" x 8'-9" (5.89 m x 1.67 m x 2.66 m)
Fuel Tank Capacity and Type	10 US gal (38 L) Gasoline
Hydraulic Tank Capacity and Fluid Type	26 US gal (102 L) Dexron III ATF & AW-64 & AW-32
Saw Bar Oil Reservoir Capacity	6 US qt (5.6 L) (Biodegradable recommended)
Tool Box – Fits medium-sized chain saw (L x W x H)	38" x 10" x 15" (97 cm x 25 cm x 38 cm)
Infeed Trough	Heavy Duty 12 ft (3.6 m) Continuous chain drive Valve operated hydraulic motor
Live Deck	Folding Two-strand with Adjustable Height; Valve-operated hydraulic motor, continuous chain drive
Live Deck Height	53" (135 cm)
Live Deck Length	70" (178 cm)
Live Deck Width	72" (182 cm)
Saw Bar and Chain	25" ,88 pcs, pitch 0.404".
Saw Drive	Hi-speed (5500 rpm) hydraulic gear motor Valve operated with adjustable feed
Through-put	1 ½ – 2 ¾ cords an hour
Full Stroke Splitting Cycle Time	6.5 seconds
Average Cycle Time (cut and split)	12 seconds

Item	FP-500H Trailer Wood Processor
Options	Hydraulic log lifter, includes powered live deck lift
Accessories	Adjustable operators seat and platform
	48" (1.2 m) Log peavey
	Firewood net
	Firewood net frame
	Hydraulic 8' (2.4 m) off-loading conveyor Winch-adjustable height; Maximum 50° swing.
	Hydraulic 12' (3.6 m) off-loading conveyor Winch-adjustable height; Maximum 50° swing
	Powered top roller (dealer installed)
	6-way splitting wedge

11.1 Common Bolt Torque Values

Checking Bolt Torque

The tables shown give correct torque values for various bolts and capscrews. Tighten all bolts to the torque values specified in the table, unless indicated otherwise. Check tightness of bolts periodically.

IMPORTANT! If replacing hardware, use fasteners of the same grade.

IMPORTANT! Torque figures indicated in the table are for non-greased or non-oiled threads. Do not grease or oil threads unless indicated otherwise. When using a thread locker, increase torque values by 5%.

 **NOTE:** Bolt grades are identified by their head markings.

Imperial Bolt Torque Specifications						
Bolt Diameter	Torque Value					
	SAE Gr. 2		SAE Gr. 5		SAE Gr. 8	
	lbf·ft	N·m	lbf·ft	N·m	lbf·ft	N·m
1/4"	6	8	9	12	12	17
5/16"	10	13	19	25	27	36
3/8"	20	27	33	45	45	63
7/16"	30	41	53	72	75	100
1/2"	45	61	80	110	115	155
9/16"	60	95	115	155	165	220
5/8"	95	128	160	215	220	305
3/4"	165	225	290	390	400	540
7/8"	170	230	420	570	650	880
1"	225	345	630	850	970	1320



Metric Bolt Torque Specifications				
Bolt Diameter	Torque Value			
	Gr. 8.8		Gr. 10.9	
	lbf·ft	N·m	lbf·ft	N·m
M3	0.4	0.5	1.3	1.8
M4	2.2	3	3.3	4.5
M6	7	10	11	15
M8	18	25	26	35
M10	37	50	52	70
M12	66	90	92	125
M14	83	112	116	158
M16	166	225	229	310
M20	321	435	450	610
M30	1,103	1 495	1,550	2 100



11.3 Hydraulic Fitting Torque

Tightening Flare Type Tube Fittings

1. Check flare and flare seat for defects that might cause leakage.
2. Align tube with fitting before tightening.
3. Hand-tighten swivel nut until snug.
4. To prevent twisting the tube, use two wrenches. Place one wrench on the connector body and tighten the swivel nut with the second. Torque to values shown.

If a torque wrench is not available, use the FFFT (Flats From Finger Tight) method.

Hydraulic Fitting Torque					
Tube Size OD	Hex Size Across Flats	Torque value		Flats From Finger Tight	
		lbf•ft	N•m	Flats	Turns
3/16	7/16	6	8	2	1/6
1/4	9/16	11–12	15–17	2	1/6
5/16	5/8	14–16	19–22	2	1/6
3/8	11/16	20–22	27–30	1-1/4	1/6
1/2	7/8	44–48	59–65	1	1/6
5/8	1	50–58	68–79	1	1/6
3/4	1-1/4	79–88	107–119	1	1/8
1	1-5/8	117–125	158–170	1	1/8

Values shown are for non-lubricated connections.

11.2 Wheel Lug Nut Torque



Loose wheel lug nuts can result in broken studs, risking the wheel coming off the axle hub. Keep lug nuts torqued to proper specification.

Maintaining proper wheel lug torque on your trailer axle is an extremely important safety measure. Always use a properly calibrated torque wrench.

Torque wheel lug nuts before first road use and after each wheel removal. Check and re-torque after the first 10 mi (16 km), 25 mi (40 km), and again at 50 mi (80 km). Check periodically thereafter.

- Start all lugs by hand to prevent cross threading.
- Tighten lug nuts following the Wheel Lug Torque Pattern. Tighten each set of lug nuts in stages, as shown.

Wheel Lug Nut Torque				
Wheel Size	Units	1st Stage	2nd Stage	3rd Stage
8"	lbf•ft	12–20	30–35	45–55
	N•m	16–26	39–45.5	58.5–71.5
12"	lbf•ft	20–25	35–40	50–60
	N•m	26–32.5	45.5–52	65–78
13"	lbf•ft	20–25	35–40	50–60
	N•m	26–32.5	45.5–52	65–78
14"	lbf•ft	20–25	50–60	90–120
	N•m	26–32.5	65–78	117–156
15"	lbf•ft	20–25	50–60	90–120
	N•m	26–32.5	65–78	117–156
16"	lbf•ft	20–25	50–60	90–120
	N•m	26–32.5	65–78	117–156

Wheel Lug Torque Pattern

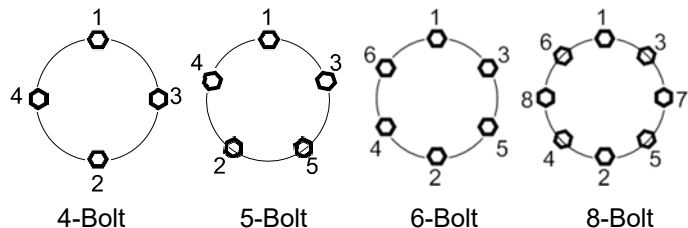

12. Accessories

12.1 Operator's Platform

An operator's seat and platform is available as an add-on accessory for the wood processor. It provides an adjustable seated work area for the operator.

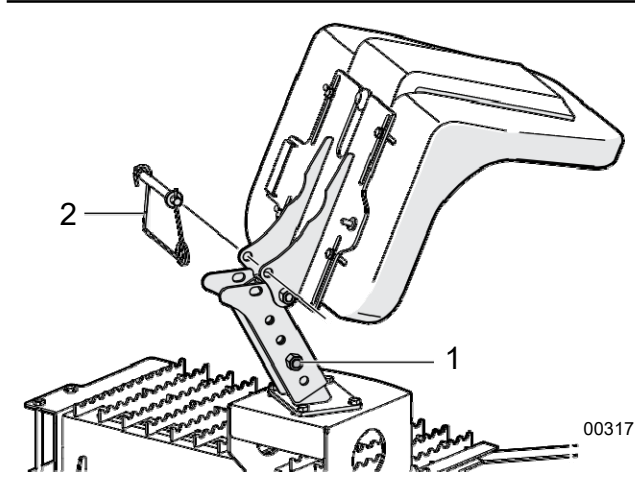

Fig. 90 – Operator's Seat

1. Height Adjuster Bolt
2. Snap Lock Pin

Adjust Seat Height

- Remove the height adjuster bolt, set the desired the height and reinsert the bolt.

IMPORTANT! When transporting the wood processor on a roadway, or when the seat is not in use, pull the snap lock pin and lean the seat over. Reinsert the pin to secure it there.

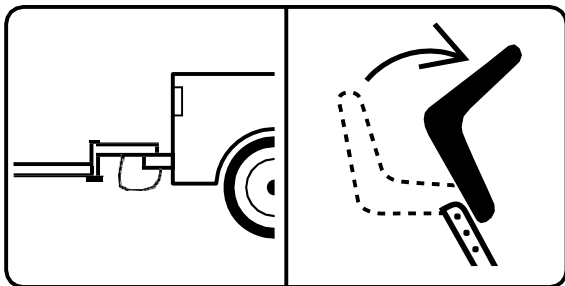

12.2 Integrated Conveyor

Accessory conveyors are available for the wood processor in 8 ft (2.4 m) and 12 ft (3.6 m) lengths. The conveyor is pinned to the rear of the wood processor and provides a 50° swing angle to stack split wood.

12.2.1 Controls

A hydraulic control valve powers the conveyor, and height is adjusted with a hand winch. The conveyor angle is changed by pulling the snap lock pin and pushing the conveyor to one side or the other.

- Push the valve lever into the detent to activate the conveyor. The conveyor chain operates at one speed.
- If the conveyor becomes jammed, it is possible to run the chain backwards for SHORT periods of time only to clear it. To do that, hold the wedge height lever all the way down. At the same time, move the conveyor control lever in the opposite direction from the detent.

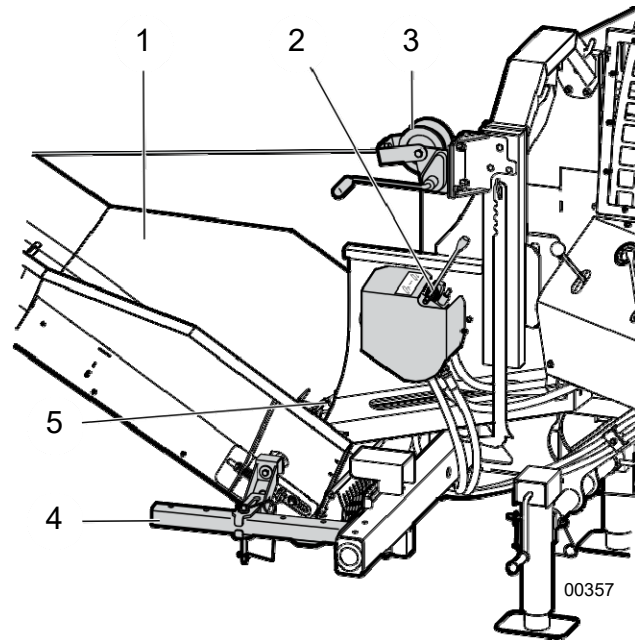

Fig. 91 – Conveyor Controls

1. Conveyor Hopper
2. Hydraulic Control Valve
3. Hand Winch
4. Conveyor Angle Guide and Snap Lock Pin
5. Conveyor Pivot

12.2.2 Change Conveyor Height

Conveyor height is adjusted using the hand winch on the left-hand side. An internal brake holds the winch at the desired height.

To raise the conveyor:

- Turn winch handle clockwise. (The winch ratchet clicks as the handle is turned.)

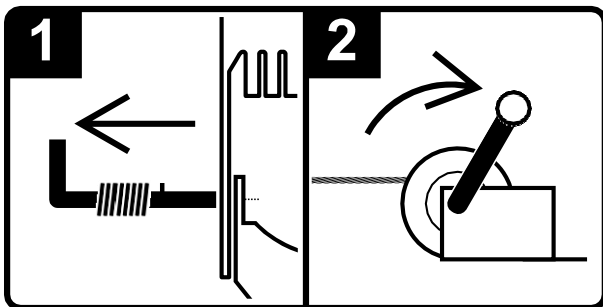

To Lower the Conveyor:

- Turn the handle counter-clockwise. (There is no clicking sound when lowering.)
- When the conveyor is at the desired height, turn the winch handle back in the clockwise direction to engage the brake until two clicks are heard.

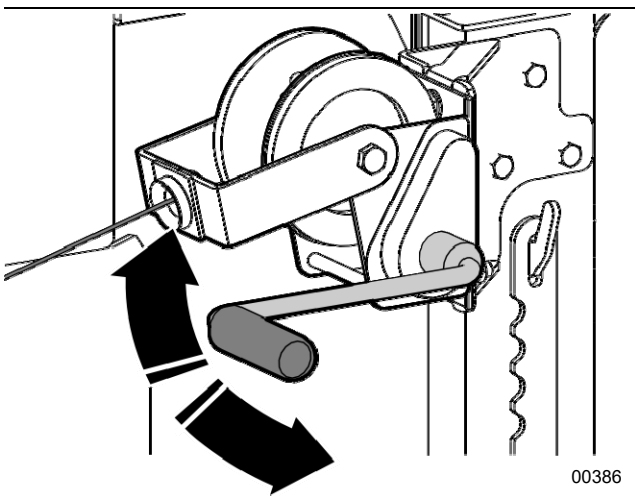

Fig. 92 – Conveyor Hand Winch

12.2.3 Change Conveyor Angle

1. Remove snap lock pin and push conveyor to right or left to the desired angle.
2. Reinsert snap lock pin.

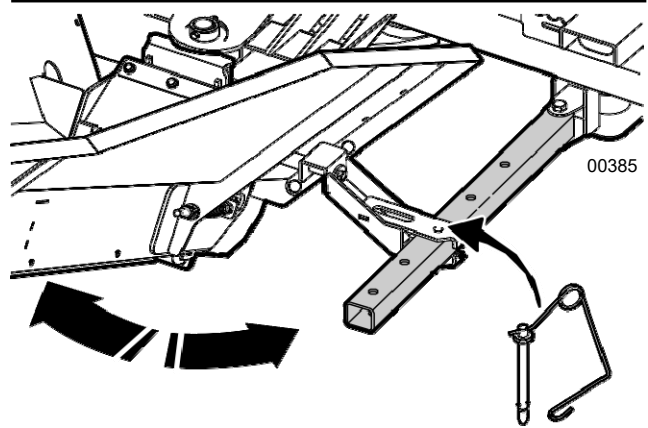

Fig. 93 – Changing Conveyor Angle

12.2.4 Conveyor Chain Tension, Adjust

The conveyor chain can stretch a slight amount and can require occasional adjustment. Care must be taken to not over adjust, as this adds pretension into the chain and reduces chain life.

IMPORTANT! The main requirement of chain adjustment is to remove slack from the chain (take up the clearances in each link). It is easy to over tighten the chain, so great care is needed!

Measure conveyor chain slack from the topside, inside the conveyor trough. The 12 ft (3.6 m) conveyor must be unfolded with side latches secured.

Pull the chain up at the middle and measure dimension X. Adjust accordingly.

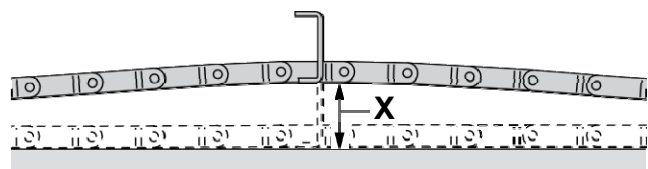

Ideal Conveyor Chain Slack (X)	
8 ft (2.4 m) Conveyor	X = 2" (5 cm)
12 ft (3.6 m) Conveyor	X = 3" (7.6 cm)

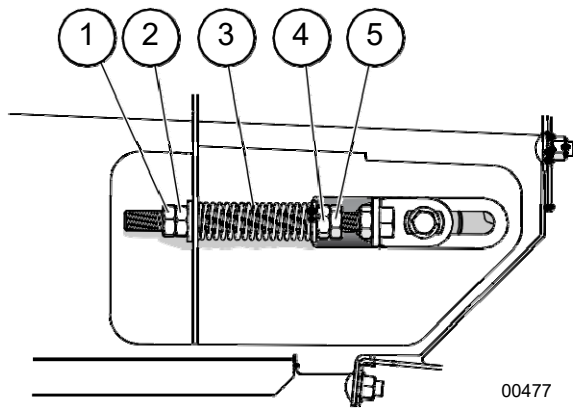



Fig. 94 – Chain Tensioner

1. Jam Nut
2. Adjuster Nut
3. Tension Spring
4. Spring Tensioner Nut
5. Tensioner Jam Nut

IMPORTANT! The tension spring (3) must be kept at the same compressed length after adjustments are made. Adjust both sides equally.

1. Loosen jam nuts (1 and 5). Loosen off adjuster nut (2).
2. Turn spring tensioner nut (4) clockwise so the spring compresses enough to increase chain tension. **Make sure both sides of the conveyor are adjusted equally.**

 **NOTE:** *It may be necessary to tap the bolt lightly to get the spring to re-adjust the tension to the new setting.*

3. Tighten adjuster nut (2).
4. Tighten jam nuts (1 and 5).

12.2.5 Transporting

- The 8 ft (2.4 m) model can be winched up to a vertical position when transporting the wood processor on a roadway.
- The 12 ft (3.6 m) conveyor is hinged and folds up for transport.

13. Alphabetical Index

A		Job Site Familiarization.....	21
Accessories	69	Operator Orientation	21
Integrated Conveyor		To the New Operator.....	21
Controls	69	Fluids	51
Adjust Block Dropper	32	Fuel Level – Checking	36
Adjust Wedge Height	45	G	
Air Cleaner Inspection	56	Gas Motor Safety	13
Attaching and Unhooking.....	48	Grease	51
B		Greasing	53
Bar Chain, Remove / Replace	59	H	
Bar Chain, Tensioning.....	60	Hookaroon	42
Bar Oil Flow Rate.....	45	How to Install Safety Signs	20
Battery Safety	13	Hydraulic Controls.....	24
Before Starting the Engine.....	35	Hydraulic Fitting Torque.....	68
Block Dropper	31	Hydraulic Oil.....	51
Breakaway Cable.....	49	Hydraulic Oil Level Check	37
Break-in	38	Hydraulic Oil Tank Capacity	54
Bubble Level on Frame.....	26	Hydraulic System Safety.....	11
C		I	
Chain Saw Bar Oil	37	Ignition Switch.....	23
Chain Saw Safety	13	Infeed Conveyor.....	42
Checking Bolt Torque.....	67	Infeed Conveyor Chain, Tensioning.....	61
Choke	23	Infeed Conveyor Control	25
Choke, operating	23	Informative Labels.....	7
Common Bolt Torque Values	67	Integrated Conveyor	69
Controls		Conveyor Chain Tension, Adjust	70
Choke	23	Introduction	2
Engine Controls	23	J	
Hour Meter.....	23	Jump Starting.....	57
Hydraulic Controls	24	L	
Infeed Conveyor Control.....	25	Live Deck	40
Live Deck Feed Control	25	Live Deck Feed Control.....	25
Log Lifter Shelf Control.....	25	Log Lifter	41
Saw Lowering Speed Control	25	Log Lifter Shelf Control	25
Splitter Cylinder Control Valve.....	24	Lowering Live Deck.....	27
Splitting Wedge Height Control.....	25	Lowering Live Deck with Log Lifter.....	28
Top Roller Lock	25	Lubricants	51
Ignition Switch	23	M	
Controls, Integrated Conveyor.....	69	Machine Components.....	22
Conveyor Angle, Changing	70	Machine Dimensions.....	50
Conveyor Chain Slack	70	Machine Set-up.....	26
Conveyor Chain Tension, Adjust	70	Adjust Block Dropper	32
Conveyor Controls	69	Block Dropper	31
Conveyor Height, Changing.....	70	Integrated Conveyor Set-up.....	33
Cutting	44	Log Stop Guide	32
D		Lowering Live Deck.....	27
Decal Information.....	7	Lowering Live Deck with Log Lifter.....	28
Delivery Inspection Report	4	Making the Work Area Safe	34
E		Positioning Machine at Site.....	26
Emergency Stopping	39	Raising Live Deck with Log Lifter	31
Engine	51, 56	Saw Shield	33
Engine Air Cleaner.....	56	Maintenance Schedule	52
Engine Controls	23	Making the Work Area Safe	34
Engine Throttle	23	Measure conveyor chain slack.....	61, 62, 70
Engine Fuel.....	51	O	
Engine Oil	51	Operating Safety	10
Engine Oil Level Check	36	Operation	39
Engine throttle, operating.....	23	Cutting	44
Equipment Safety Guidelines.....	10, 11	End of the Log.....	46
Every 8 hours or Daily.....	52	Infeed Conveyor.....	42
Every 50 hours or Annually.....	52	Locking Top Roller.....	43
Every 100 hours or Annually	52	Powered Top Roller (option)	44
F		Splitting	45
Familiarization.....	21	Adjust Wedge Height	45
		Starting the Engine	39

Stopping in an Emergency	39
Stopping Procedure	39
Operator Orientation	21
Operator's Platform	69

P

Personal Protective Equipment (PPE)	9
Pre-start Checks	35
Before Starting the Engine	35
Chain Saw Bar Oil	37
Engine Oil Level Check	36
Fuel Level Check	36
Hydraulic Oil Level Check	37
Pre-Operation Checklist	35
Saw Chain	37

R

Raise Top Roller	43
Raising Live Deck with Log Lifter	31
Refueling	36
Refuelling Safety	12
Replace Damaged Safety Signs	20

S

Safe Condition	9
Safety	8
Battery Safety	13
Chain Saw Safety	13
Equipment Safety Guidelines	10, 11
Gas Motor Safety	13
How to Install Safety Signs	20
Hydraulic System Safety	11
Operating Safety	10
Personal Protective Equipment (PPE)	9
Refuelling Safety	12
Safety Alert Symbol	8
Safety Training	11
Signal Words	8
Storage Safety	12
Tire Safety	12
Transport Safety	12
Safety Alert Symbol	8
Safety Notice Decals	7
Safety Signs	16
Safety Training	10, 11
Saw Chain Maintenance	59
Saw Lowering Speed Control	25
Saw Lubrication	60
Seat Height Adjust	69
Serial number	5
Service and Maintenance	51
Axles	58
Electrical System	58
Engine	56
Hydraulic Oil – Changing	54
Clean Suction Strainer	54
Hydraulic Oil Filter - Changing	55
Infeed Conveyor Chain, Tensioning	61
Live Deck Drive Chain Lubrication	62
Saw Chain Maintenance	59
Bar Chain, Remove / Replace	59
Bar Chain, Tensioning	60
Sharpening	59
Saw Lubrication	60
Servicing the Battery	57
Charging the Battery	57
Cleaning the Battery	57
Installing the Battery	57
Jump Starting	57
Removing the Battery	57
Splitting Wedge – Changing	61
Storing Lubricants	51
Set Log Stop Guide	32

Sharpening Saw Chain	59
Sign-off form	15
Specifications	65
Common Bolt Torque Values	67
Hydraulic Fitting Torque	68
Splitter Circuit Hydraulic Pressure Gauge	24
Splitter Cylinder Control Valve	24
Splitting	45
Splitting Wedge – Changing	61
Splitting Wedge Height Control	25
Starting Procedure	39
Stopping	39
Stopping in an Emergency	39
Storage	51
Removing From Storage	51
Storage Safety	12

T

Tightening Drive chains	
Live Deck	62
Live Deck Drive	62
Top Roller Lock	25
Trailer Breakaway System	49
Transporting	47
Attaching and Unhooking	48
Machine Dimensions	50
Raising Live Deck	48
Trailer Breakaway System	49
Transporting on a Roadway	49
Transporting, Integrated Conveyor	71
Troubleshooting Guide	63

U

Unhooking	48
-----------------	----

W

Warranty	6
Wheel Lug Nut Torque	68



A series of horizontal lines for writing, starting with two lines that are slightly indented from the left margin, followed by a continuous series of lines down the page.